

sewoo

Aroot Co., Ltd.

28-6, Gajangsaneopdong-ro, Osan-si, Gyeonggi-do, 18103, Republic of Korea
TEL +82-31-8077-5000 / FAX +82-31-624-5310 / <http://www.miniprinter.com>

SEWOO



LABEL PRINTER

MODEL : LK-B24

4" Thermal Transfer and Direct Thermal Label Printer

All specifications are subject to change without notice

**This device complies with part 15 of the FCC Rules.
Operation is subject to the following two conditions.**

- 1) This device may not cause harmful interference, and
- 2) This device must accept any interference received, including interference that may cause undesired operation.

Vic Barczyk

20280 S. Vermont Ave. STE 200, Torrance, CA 90502 | USA
sales@miniprinter.com

Henning Mahlstedt

26188 Edeweicht, Holljestr.9 | Germany
europe@miniprinter.com

Victor Almazan

Paseo de la Reforma No. 265 Piso 2.Oficina SBC. Col.
Cuauhtémoc, C.P. 06500 Ciudad de Mexico | Mexico
sales@miniprinter.com

Yan xiao rui

Room 902, No. 7, Lane 118, Xiaojishan Road, Sheshan Town,
Songjiang District, Shanghai | China
sales@miniprinter.com



Disposal of Old Electrical&Electronic Equipment(Applicable in the European Union and other European countries with separate collection systems)

This symbol on the product or on its packaging indicates that this product shall not be treated as household waste. Instead it shall be handed over to the applicable collection point for the recycling of electrical and electronics equipment. For more detailed information about recycling of this product, please contact your local city office, your household waste disposal service or the shop where you purchased the product.

Table of Contents

Safety Precautions	2
1. Unpacking	4
2. Inspecting The Printer	5
3. Attaching Power Supply	7
4. Hooking up the printer and computer	8
5. Loading the Paper	9
6. Loading Ribbon	11
7. The treatment when you run short of paper and encounter cutter jam proble	13
8. Setting up the sensors	14
9. Self-Test	15
10. Sensor Calibration	16
11. Pause function	17
12. Printer cleaning	18
13. Connector	19
14. Standard roll media specification	21
15. Standard label specification	22
16. Label specification with Through-hole	23
17. Label with Black Mark	24
18. Continuous stock specification	25
19. Specifications	26
20. Command List	28
21. Utilities	31
22. S/W	32

Safety Precautions

For better safety and reliability, adhere to the following precautionary measures. Read and follow the instructions carefully before operation of the product.

Indication



Prohibition



Must follow



Do not disassemble



Unplug the power from the outlet



Grounding to prevent electric shock



Do not handle the product with wet hands



WARNING

Failure to follow these instructions could result in fire, electric shock, other injuries, or property damage.



Do not pull or touch the power plug with wet hands.

Potential risk of electric shock or fire



Do not bend the wire and do not allow the wire to be pinched or crushed by heavy objects.

Potential risk of electric shock or fire

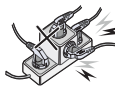

Do not overload an electrical outlet.

Potential risk of electric shock or fire



If a power plug is broken or a plug is cut or worn, do not use it.

Potential risk of electric shock or fire





WARNING

Failure to follow these instructions could result in fire, electric shock, other injuries, or property damage.



Do not unplug the power cable to turn off the product.

Turn off the power using the power button



Do not disassemble, repair or modify the product.

Potential risk of malfunction, electric shock, or fire. When the product needs to be repaired, please contact your reseller



CAUTION

Failure to follow these instructions could result in fire, electric shock, other injuries, or property damage.



Do not install the product on an unstable or inclined surface.

May cause damage or injury



If the product needs to be repaired, please contact your reseller.

Potential risk of fire or unit malfunction



Keep product away from the water and other material.

Potential risk of fire or unit malfunction

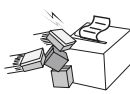

Avoid excessive shock or drops.

Potential risk of fire or property damage



1. Unpacking

Standard

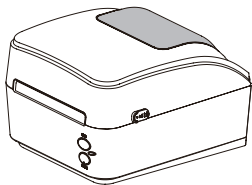

Printer

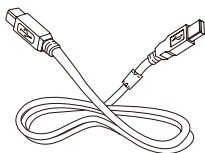

Interface cable (USB)

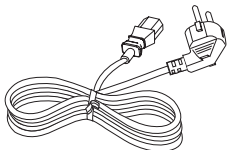

Power Cord(1EA)

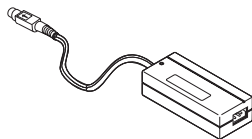

Power supply

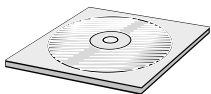

CD (Manual and Software)

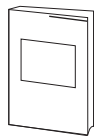

Quick Manual

2. Inspecting The Printer

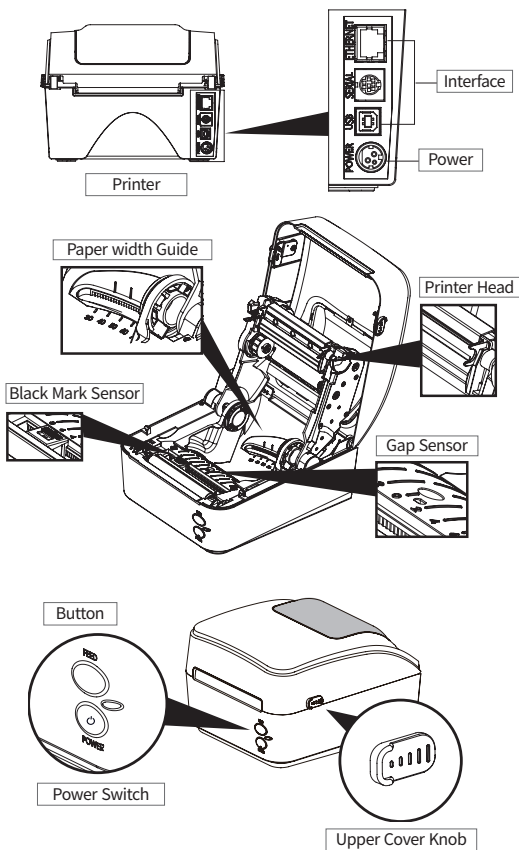

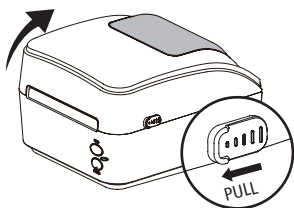

Open the upper cover by pushing the knob in the direction of the arrow

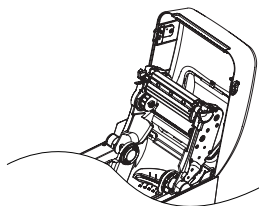

CAUTION

Make sure to be careful of the HOT head after using long time.

1 2
3

" If the cover is not shut down completely,
the printer may not work properly

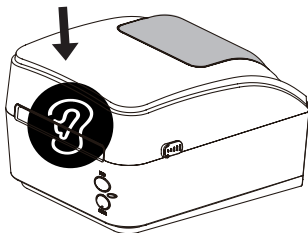

Please make sure you hear the closing sound of the upper cover.

3. Attaching Power Supply

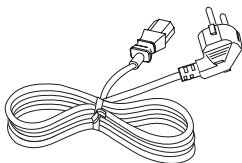

Please check the specification of the AC power cord if it is correct with your power system.

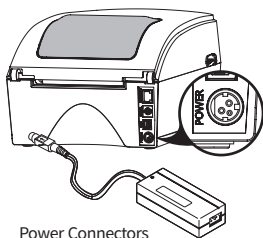

Power Connectors

Turn off the power of the printer and connect the power supply to the printer as shown above.

1 2
3 4

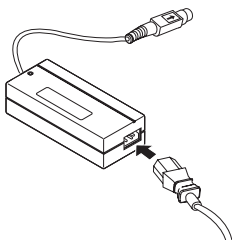

Connect the AC power cord to the power supply.

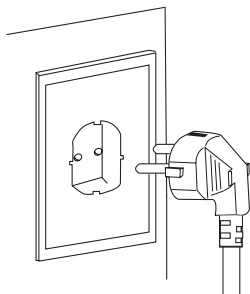

Insert a plug into the Telectrical outlet.

4. Hooking up the printer and computer

Printer

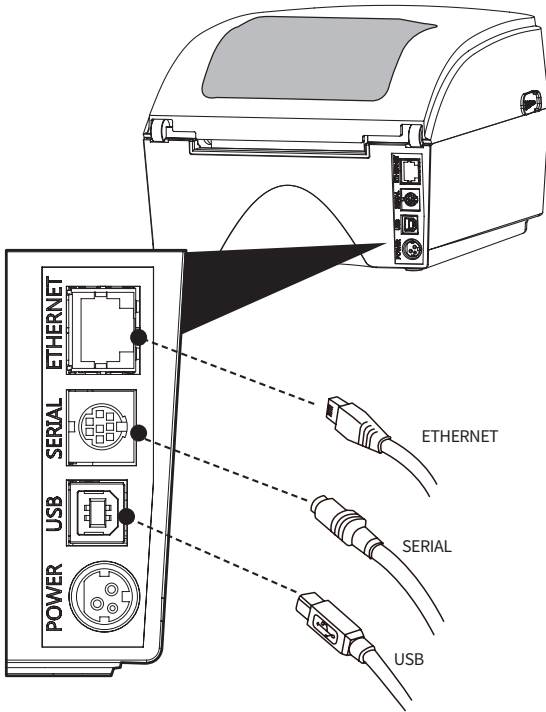

5. Loading the Paper

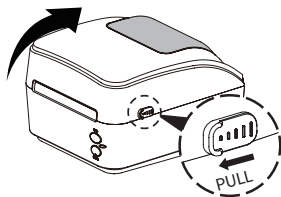

Turn off the printer and open the upper cover by pushing the knob in the direction of the arrow

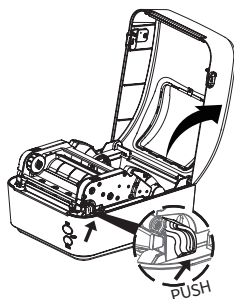

Please open the upper cover as shown above.

1 2
3 4

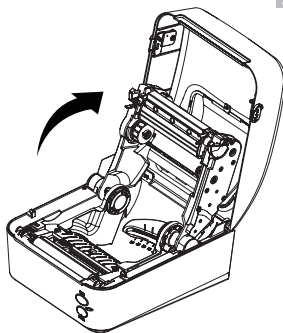

Please open as shown above.

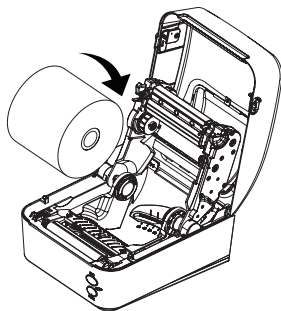

Insert the paper roll into the printer.

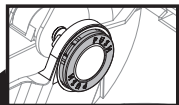
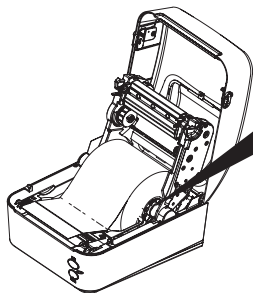

– Change paper core size adjusting push button of Label Paper Guide.

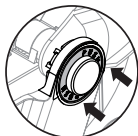

– 1 inch –

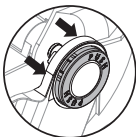

– 1.5 inch –

Adjust the paper width guide to meet the paper width.

5
6

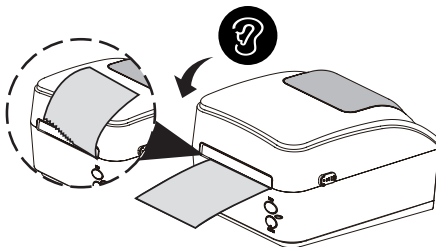

Close the upper cover completely and make sure you hear the closing sound.

– Please cut the paper in upper direction.

6. Loading Ribbon

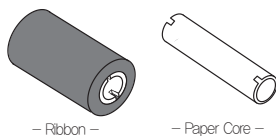
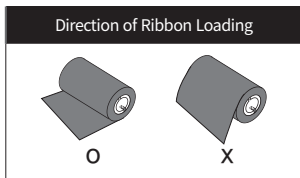

Prepare a ribbon and paper core

Make sure that install adjusting the groove.

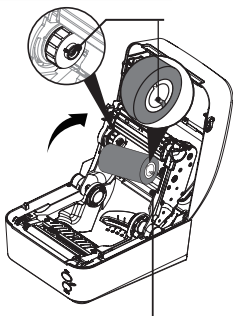

Install the ribbon to the right side first

Install the ribbon adjusting the groove after lifting following picture.

1 2
3 4

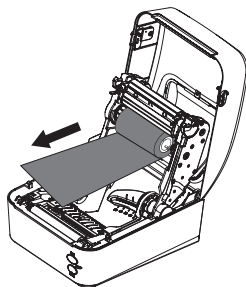

Release the ribbon forward enough.

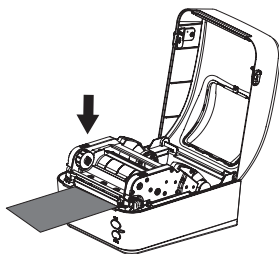

Close in condition that the ribbon is released.

Install a paper core adjusting the groove, otherwise a paper core can be fallen.

New ribbon has sticker in the end, so that tape is not necessary. In case that ribbon doesn't have sticker, please use tape.

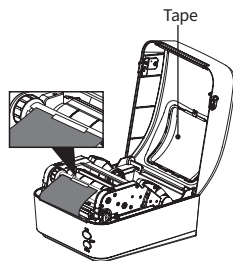
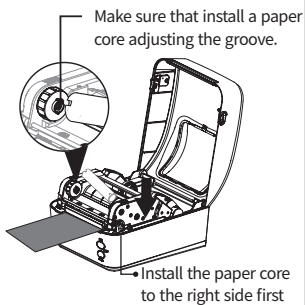

Install a paper core adjusting the groove as picture.

Attach the ribbon using tape to a paper core as picture.

1 2
3 4

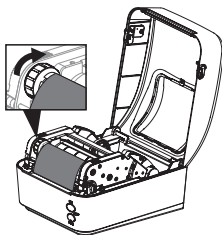

Spin the roller tight in order that only black side of the ribbon is appeared.

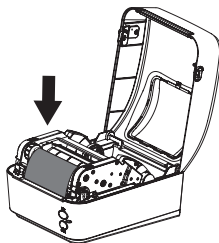

Close exactly with click sound.

7.The treatment when you run short of paper and encounter cutter jam problem

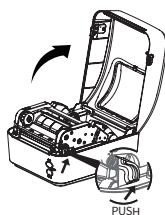
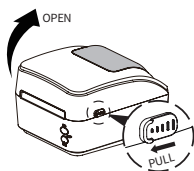

While you are printing with continuous media, please press PULL lever to the direction of the arrow.

" Installation of the new paper when the printer is short of it "

" Remove of the paper seized by paper jam "

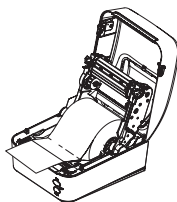
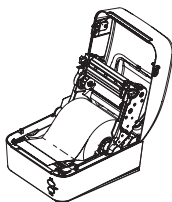

Please open as shown above.

Insert the paper roll into the printer.

" Remove of the paper seized by paper jam "

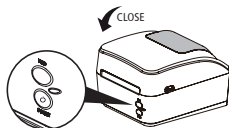

After the treatment has been done as picture above, the printer function normally once you press FEED button.



When the power is on, the ordered data will be printed without any data lost after installation of the new paper roll or treatment for paper Jam.

However, if these action has been done in the case the power is off, there can be some data lost since the printer buffer will not save them while the printer power is off.

8. Setting up the sensors

Black Mark Sensor

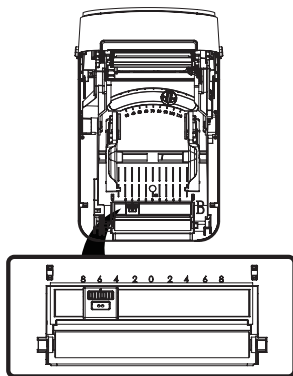

Set Black Mark Sensor right to the size of roll paper

GAP Sensor

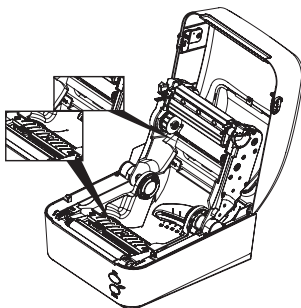

9. Self-Test

✓ NOTE

- Power switch sig **ON** : Press once.
OFF : During 2~3 seconds.

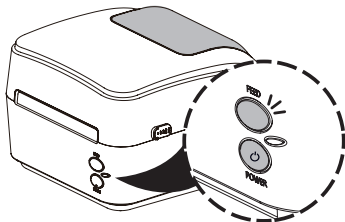

Regardless of the power status (Power ON or Power OFF), press and hold the Power button and the Feed button for 2~3 seconds at the same time to print the printer information.

1
2

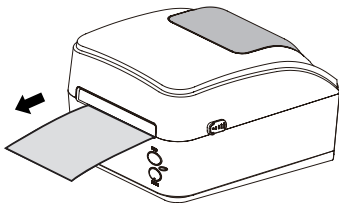

Feeding will be performed automatically after general information is printed, then now printing is possible.

10. Sensor Calibration

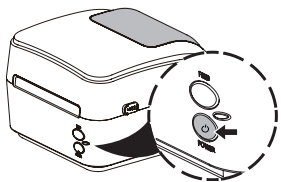

Press the POWER button to turn the printer on.

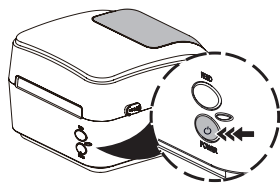

After that, press thr POWER button 3 times.

1 2
3

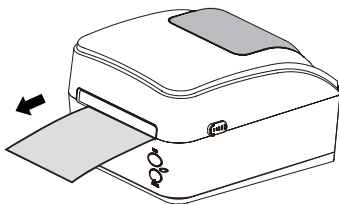

The printer will be stopped after a graph is printed. Then, you can use the printer.

If the calibration result is abnormal, set it up in "SEWOO Label Printer Configuration Tool" and then try again. This utility is on the CD and can be downloaded from the homepage.

11. Pause function

✓ NOTE

- **Pause & Restart** : Press FEED KEY Once.

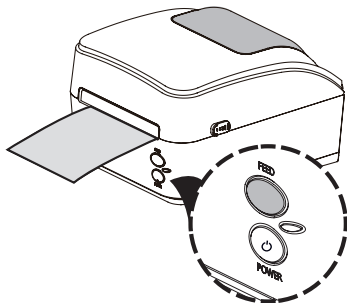

When you would pause on the printing process, press the 'FEED' key.

12. Printer cleaning

If the interior of the printer is dusty, printing quality can lowered. In such a case, follow the instructions below to clean up the printer.

✔ NOTE

- 01 Make sure to turn the printer power off prior to cleaning.
- 02 Regarding printhead cleaning, as the printhead gets very hot during printing, turn off the printer power and wait approximately 10 minutes before cleaning.
- 03 When cleaning the printhead, take care not to touch the heated portion of the printhead. The printhead can be damaged by static electricity.
- 04 Take care not to allow the printhead to become scratched and / or damaged in any way.

Print-Head Cleaning

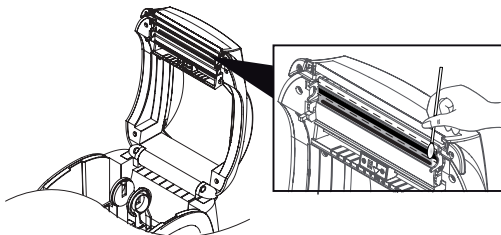

- 1 Use an applicator swab moistened with an alcohol solution to clean the print head and remove any dusts.
- 2 Once the cleaning is completed, insert paper roll into the printer few minutes later and close the printer cover.

13. Connector

Interface Connectors

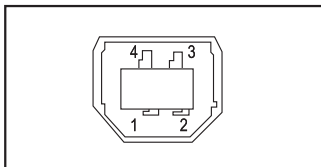

USB " B " TYPE

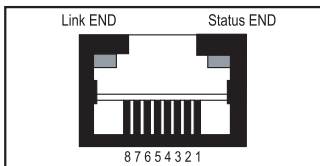

Ethernet

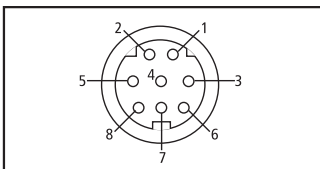

8 Pin Serial

Ethernet Interface

Pin	Signal	I/O
1	Data Out +	Output Data +
2	Data Out -	Output Data -
3	GND	Ground
4	Data IN +	Input Data +
5	Data IN -	Input Data -
6	N.C	-
7	N.C	-
8	N.C	-

USB Interface

Pin	Signal	I/O	Description
1	+5V	-	+5V
2	DATA-	-	Printer transmit data line
3	DATA+	-	Printer transmit data line
4	GND	-	System Ground

DIN 8Pin Serial Interface

Pin	Signal	I/O	Description
1	RXD	Input	Printer receive data line RS-232C level
2	TXD	Output	Printer transmit data line RS-232C level
3	DTR	Output	Printer handshake to host line RS-232C level
4	GND	-	System Ground
5	DSR	Input	Data Send Ready
6,8	NC	-	-

14. Standard roll media specification

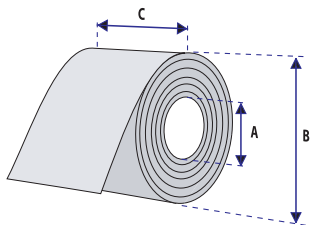

Core	
Diameter(A)	25.4 or 38.1 mm
Max. width	114 mm
Roll	
Max.diameter(B)	127 mm
Max.media width(C)	114 mm
Min.media width(C)	18 mm
Max.media thickness	0.20 mm
Min.mdeia thickness	0.06 mm

NOTE

- 01 If the label thickness is more than 0.18mm, adjust the printing speed to 127mm/s.
- 02 When the paper width is less than 25.4 (1inch), please print 101.6 mm/s
When the paper width is between 25.4 (1inch) to 76.2 (3inch), please print 127mm/s.



Protect the printhead from sand, grit, and other hard particles during printing and storage. Keep the cover closed.
Even very small foreign particles may cause severe harm to the printhead.

15. Standard label specification

<- a --> Media width (inch, liner)	
Maximum	114 mm
Minimum	18 mm
<- b --> Label length	
Minimum	10 mm
<- c --> Label gap height	
Maximum	10 mm
Minimum	2 mm
Liner	
Opacity	50~75%

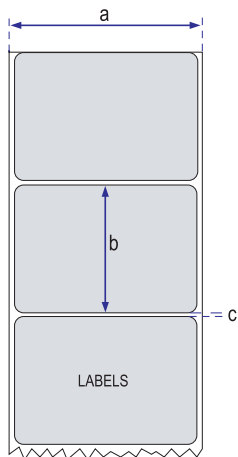

16. Label specification with Through-hole

<- a -> Tag or strip width	
Maximum	114 mm
Minimum	18 mm
<- b -> Tag length	
Minimum	10 mm
<- c -> Detection slot width	
Minimum	14 mm
<- d -> Detection slot height	
Maximum	10 mm
Minimum	2 mm

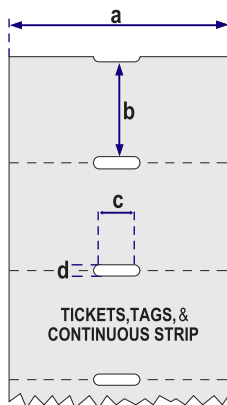

17. Label with Black Mark

<-- a --> Tag or strip width	
Maximum	114 mm
Minimum	18 mm
<-- b --> Tag length	
Minimum	10 mm
<-- c --> Black mark width	
Minimum	14 mm
<-- d --> Black mark height	
Maximum	10 mm
Minimum	3 mm

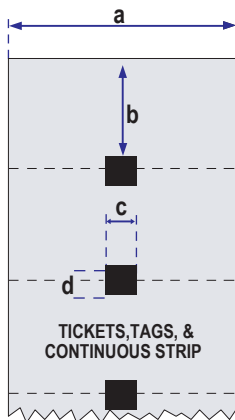

18. Continuous stock specification

The printer can use continuous paper without any detection gap or black marks.
Continuous paper cannot be used in the Test (Dump) Mode.

<- a ->	
Maximum	114 mm
Minimum	18 mm



19. Specifications

Print method		Direct Thermal
Print speed (Max.)		127mm/sec
Print width (Max.)		104mm (4 inch)
Print length (Max.)		1,000mm
Resolution		203dpi (8 dots/mm)
Paper width (Min.~Max.)		Min. 18 ~ Max. 114 mm
Paper roll size (Min.~Max.)		Ø 25.4 mm ~ Ø 127 mm
Paper thickness		0.06 ~ 0.20 mm
Paper type		Label , Tag, Continuous, Fanfold
Paper sensor		Label Gap, Black Mark, Ribbon Encoder
Ribbon width (outside diameter)		110mm
Ribbon length		74M, Ø 33 mm
Ribbon diameter		0.5 inch
Interface		Serial(RS-232C), Ethernet, USB
Memory	Standard	1MB Flash, 16MB SDRAM, 8MB Font Flash
Serial baud rate		115,200 bps (max)
Programming language		EPL II (Eltron Programming language) ZPL II (Zebra Programming language)
Barcode	1D	Code39, Code128 with subsets A/B/C, Code93, Codabar, Interleaved 2 of 5, UPC-A and UPC-E with 2 or 5 digit extensions, EAN-8 and EAN-13 with 2 or 5 digit extensions, Postnet, Plessey(MSI-1), German Post Code, MSI-3, UCC/EAN-128, Logmars, Code49
	2D	MaxiCode, PDF 417, Data Matrix, QR Code, MicroPDF417, AZTEC
Font specification	EPLII	6bitmapped Font
	ZPLII	7bitmapped Font, 1 Smooth Font
Weight		1.9 2kg
Size (W x D x H)		207 x 250.50 x 160.65 mm

Temperature	Operation	0 ~ 40°C
	Storage	-20 ~ 60°C
Humidity	Operation	10 ~ 90%
	Storage	10 ~ 90%

Electrical Characteristics

- 1 Input Voltage DC 24V ± 10%
- 2 Current Consumption – Operating: Approx. 2.9 A (at ASC // printing)
 – Peak : Approx. 10 A
 (at print duty 100%, For 10 seconds or less)
 – Stand-by : Approx. 0.15 A
- 3 Power Connector

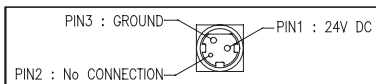

20. Command List

ZPL Command List

No.	Command	Description
1	^A	Scalable/Bitmapped Font
2	^B1	Code 11 BarCode
3	^B2	Interleaved 2 of 5 BarCode
4	^B3	Code 39 BarCode
5	^B4	Code 49 BarCode
6	^B5	Planet Code BarCode
7	^B7	PDF417 BarCode
8	^B8	EAN-8 BarCode
9	^B9	UPC-E BarCode
10	^BA	Code 93 BarCode
11	^BC	Code 128 BarCode(Subsets A, B, and C)
12	^BD	UPS MaxiCode BarCode
13	^BE	EAN-13 BarCode
14	^BF	Micro-PDF417 BarCode
15	^BI	Industrial 2 of 5 BarCode
16	^BJ	Standard 2 of 5 BarCode
17	^BK	ANSI Codabar BarCode
18	^BL	LOGMARS BarCode
19	^BM	MSI BarCode
20	^BP	Plessey BarCdoe
21	^BQ	QR Code BarCode
22	^BS	UPC/EAN Extensions
23	^BU	UPC-A BarCode
24	^BX	Data Matrix BarCode
25	^BY	BarCode Field Default
26	^BZ	POSTNET BarCode
27	^CC	~CC Change Carets
28	^CD	~CD Change Delimiter
29	^CF	Change Alphanumeric Default Font
30	^CI	Change International Font/Encoding
31	^CT	~CT Change Tilde
32	^DF	Download Format

33	~DG	Download Graphics
34	^FB	Field Block
35	^FC	Field Clock(for Real-Time Clock)
36	^FD	Field Data
37	^FH	Field Hexadecimal Indicator
38	^FN	Field Number
39	^FO	Field Origin
40	^FP	Field Parameter
41	^FR	Field Reverse Print
42	^FS	Field Separator
43	^FT	Field Typeset
44	^FV	Field Variable
45	^FW	Field Orientation
46	^FX	Comment
47	^GB	Graphic Box
48	^GC	Graphic Circle
49	^GD	Graphic Diagonal Line
50	^GE	Graphic Ellipse
51	^GF	Graphic Field
52	^GS	Graphic Symbol
53	^ID	Object Delete
54	^IL	Image Load
55	^IM	Image Move
56	^IS	Image Save
57	^LH	Label Home
58	^LL	Label Length
59	^LR	Label Reverse Print
60	^LS	Label Shift
61	^LT	Label Top
62	^MC	Map Clear
63	^MD	Media Darkness
64	^MM	Print Mode

65	^MN	Media Tracking
66	^MT	Media Type
67	^PM	Printing Mirror Image of Label
68	^PO	Print Orientation
69	^PQ	Print Quantity
70	^PR	Print Rate
71	^PW	Print Width
72	^SC	Set Serial Communications
73	~SD	Set Darkness
74	^SN	Serialization Data
75	^ST	Set Date and Time(for Real-Tiime Clock)
76	^XA	Start Format
77	^XF	Recall Format
78	^XG	Recall Graphic
79	^XZ	End Format

21. Utilities

The following utilities and concerned manual can be found on the CD or homepage.

No.	Name	Description
1	SEWOO Label Printer Configuration Tool	SEWOO Label Printer Configuration Tool. This program provides the following functions. <ul style="list-style-type: none">– Set Ethernet and RS232– Set beep sound for each error– Set detailed sensor calibration conditions– Set the print density, speed, tear-off amount after printing, and operation at booting & cover close action– Download the printer firmware– Download the resident font
2	SEWOO Label Printer Wi-Fi	This program provides detailed Wi-Fi setting functions.
3	SEWOO Label Printer Bluetooth Configuration Tool	This program provides detailed Bluetooth setting functions.
4	Font Downloader (ZPL supported)	This program provides a function to download the device system font to the printer.
5	LabelCooker	This program is for label form design and designed label printing.
6	ImageConverter (ZPL supported)	This program provides a function to download images or logos.

22. S/W

We provides SDK, Driver, etc. as follows to respond to various S/W usage environments.

You can download this S/W from the homepage.

No	Name	Description
1	Windows Driver	This is an install program used to print a label printer in Windows OS. After installing the Windows Driver, you can use a program like Label Cooker.
2	Mac Driver (EPL supported)	This is the Cups Driver used to print a label printer in the Mac OS environment.
3	Windows SDK	This is library for communication and data output with label printer in Windows OS. A method that can be used after installing Windows Driver (Windows GDI & Spool SDK) and a method to use without driver installation (Windows Direct SDK) are provided.
4	Android SDK	This is library for communication and data output with label printers in Android OS.
5	iOS SDK	This is library for communication and data output with label printers in iOS.

PATENT

