

BIXOLON®

User's Manual
XT5-40 Series

Industrial Label Printer
Ver. 1.04



<http://www.bixolon.com>

Introduction

XT5-40 series printers have been designed to be connected to various types of electronic devices such as computer peripheral devices.

※ The main features of the printer are as follows

1. Industrial Label Printer
2. Thermal Transfer / Direct Thermal Printing
3. Max 356mm/s Print Speed
4. Print Width/Length: 104mm/4,000mm(XT5-40), 105.7mm/2,500mm(XT5-43), 105.6mm/1000mm(XT5-46)
5. Media Width/Outer Diameter/Inner Diameter/Thickness: 25~114mm/203mm/ 1.5~3inch (ID 1 inch Core: Optional)/0.06~0.3mm
6. Ribbon Width/Length/Type: Max 110mm/450m/Wax, Wax Resin, Resin, Outside, Inside
7. Movable Transmissive Sensor, Movable Reflective Sensor
8. 512MByte Flash/512MByte SDRAM
9. 3.5 Inch Color Graphics TFT LCD + Keypad
10. Option: Auto Cutter, Rewinder, Peeler, 4.3 Inch Color Touch Screen TFT LCD
11. Support Interface: USB, Serial, Parallel, Ethernet, WLAN, Bluetooth

It is advisable to read the contents of this manual carefully before using the printer for the first time.

※ Use only authorized supplies that can be trusted!

- We are not responsible for quality and service for damage caused by the use of unauthorized products (or recycled ones).

TABLE OF CONTENTS

1. Content Confirmation	9
2. Product Part Names	10
2-1 Printer Part Names.....	10
2-2 Major Control Part Names(Standard Model)	13
2-2-1 Control Panel	13
2-2-2 Detailed Descriptions	14
2-3 Major Control Part Names(Touch Screen Model)	18
2-3-1 Control Panel	18
2-3-2 Detailed Descriptions	19
3. Installation & Usage	22
3-1 Printer Installation Placings	22
3-2 Power Connection	23
3-3 Interface	24
3-3-1 Standard Interface	25
3-3-2 Option Interface	26
3-4 Media Installation	27
3-4-1 Media Installation Method of Standard Model	27
3-4-2 Media Installation Method of Auto Cutter (optional) Model.....	30
3-4-3 Media Installation Method of Rewinder(optional) Model	31
3-4-4 Media Installation Method of Peeler (optional) Model	36
3-4-5 Media Installation Method of Peeler + Rewinder(optional) Model	39
3-4-6 Media Installation method for 1inch Media Core (optional) Model	46
3-4-7 How To Install Media Externally	47
3-5 How to Use Media Damper (Standard Model).....	48
3-6 Ribbon Installation.....	49
3-6-1 Ribbon Type.....	49
3-6-2 Ribbon Installation Method.....	50
3-6-3 Load Adjustment by Ribbon Length	51
3-6-4 Ribbon Remove Method	52
3-7 Print Head Load Control Method.....	53
3-8 Ribbon Guide Control Method.....	54
3-9 How to Fine Tune Print Head Position	55
4. Printer Setting.....	58
4-1 Menu Composition(Standard Model).....	58
4-2 Menu Composition(Touch Screen Model)	61
4-3 Menu Select Method(Standard Model)	64
4-4 Setting Confirm Method(Standard Model)	66
4-5 Menu Select Method (Touch Screen Model)	68
4-6 Setting Confirm Method(Touch Screen Model)	69
4-7 Setting Menu Explanation(Standard, Touch Screen Model).....	71
4-8 Interface Menu Explanation(Standard, Touch Screen Model).....	75
4-8-1 Serial.....	75
4-8-2 Ethernet	76
4-8-3 WLAN.....	77
4-8-4 Bluetooth.....	79
4-9 Sensor Menu Explanation(Standard, Touch Screen Model)	80

- 4-10 Files Menu Explanation 81
 - 4-10-1 Saved File 81
 - 4-10-2 Twin Function..... 82
 - 4-10-3 Firmware Update..... 87
- 4-11 Tools Menu Explanation(Standard, Touch Screen Model) 88
- 4-12 Info Menu Explanation(Standard, Touch Screen Model)..... 90

- 5. Maintenance..... 91**
 - 5-1 Cleaning Printer 91
 - 5-2 Cleaning Print Head 92
 - 5-3 Cleaning Platen Roller..... 93
 - 5-4 Cleaning Auto Cutter (optional) 94
 - 5-5 Cleaning Peeler Module (optional) 95

- 6. Printer Specifications 96**
 - 6-1 Specifications 96
 - 6-2 Label Types..... 96

Manual Information

This user's guide contains basic information for product usage as well as for emergency measures that may be required.

※ The following separate manuals provide more detailed content on various technological issues and areas.

1. Windows Driver Manual

This manual provides information on the installation instructions and main functions of the Windows Driver.

2. Unified Label Utility-II Manual

This manual provides information on the usage of software for function selection of this product, operating condition modification, etc.

3. Programming (SLCS) Manual

This manual provides information on label printer commands.

4. True Font Downloader Manual

This manual provides information on the usage of the font downloader that can download True Fonts and facilitate their usage as Device Fonts.

5. Network Connection Manual

This manual provides information on the configuration and usage of network.

6. Bluetooth Connection manual

This manual provides information on connection instructions the Bluetooth interface.

7. Label Design Program Manual





This manual provides information on the usage of the Windows PC program that can make labels by adding text, graphics, or barcodes at desired positions.

Safety Information

 **Warning:** Warnings must be heeded carefully in order to prevent serious physical harm.

 **Caution:** Cautions must be heeded in order to prevent minor injuries, equipment damage, or data loss.

Symbol Information

	AC (Alternating current)
	DC (Direct current)
	Note
	Caution, Warning
	USB

Safety Precautions

In using the present appliance, please keep the following safety regulations in order to prevent any hazard or material damage.



WARNING

Warnings must be heeded carefully in order to prevent serious physical harm.

Do not plug several products in one multi-outlet.

- This can provoke over-heating and a fire.
- If the plug is wet or dirty, dry or wipe it before usage.
- If the plug does not fit perfectly with the outlet, do not plug in.
- Be sure to use only standardized multi-outlets.

PROHIBIT

Use only the supplied parts for AC/DC power enclosed.

- Do not use any other AC/DC enclosed as it may incur danger.

PROHIBIT

Do not pull the cable to unplug.

- This can damage the cable, which is the origin of a fire or a breakdown of the printer.

PROHIBIT

Keep the plastic bag out of children's reach.

- If not, a child may put the bag on his head.

PROHIBIT

Do not plug in or unplug with your hands wet.

- You can be electrocuted.

PROHIBIT

Do not bend the cable by force or leave it under any heavy object.

- A damaged cable can cause a fire.

PROHIBIT



CAUTION

Cautions must be heeded in order to prevent minor injuries, equipment damage, or data loss.

If you observe a strange smoke, odor or noise from the printer, unplug it before taking following measures.

- Switch off the printer and unplug the set from the mains.
- After the disappearance of the smoke, call your dealer to repair it.

TO UNPLUG



Keep the desiccant out of children's reach.

- If not, they may eat it.

PROHIBIT



Install the printer on the stable surface.

- If the printer falls down, it can be broken and you can hurt yourself.

PROHIBIT

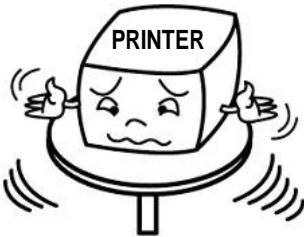

Use only approved accessories and do not try to disassemble, repair or remodel it for yourself.

- Call your dealer when you need these services.
- Do not touch the blade of auto cutter.

DISASSEMBLING PROHIBITED

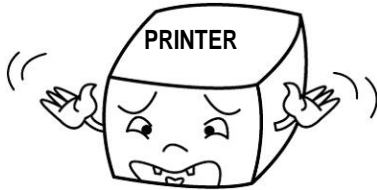

Do not let water or other foreign objects in the printer.

- If this happened, switch off and unplug the printer before calling your dealer.

PROHIBIT



Do not use the printer when it is out of order. This can cause a fire or an electrocution.

- Switch off and unplug the printer before calling your dealer.

TO UNPLUG



1. Content Confirmation

The following items should all be contained in the printer package.
Contact the dealer from which the purchase was made if any item is damaged and/or missing.

- Product

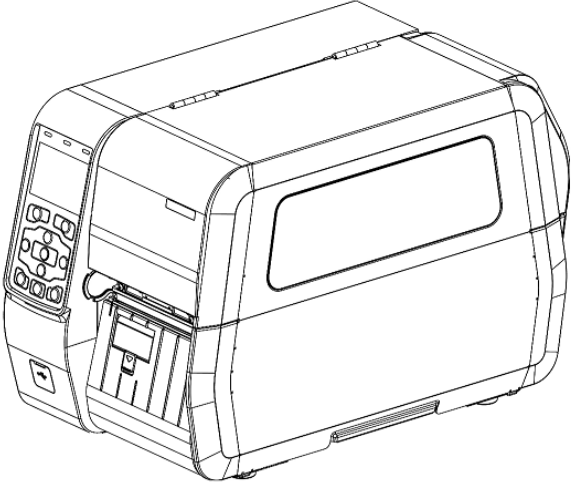

XT5-40 Series

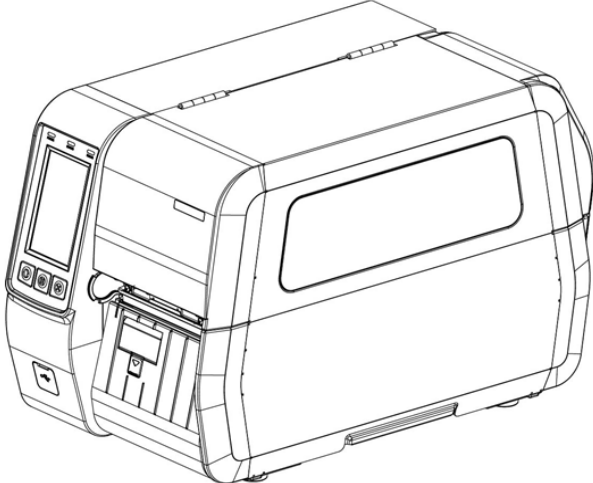

XT5-40 Touch Screen Model(Optional)

- Basic Components

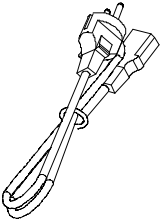

Power Cord

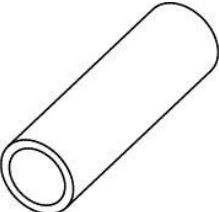

Ribbon Core

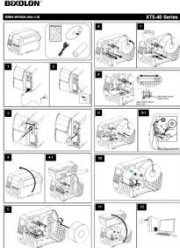

Quick Manual

- Option Components



Serial(RS-232C) Cable



Parallel(IEEE1284) Cable



USB Cable

2. Product Part Names

2-1 Printer Part Names

- Front

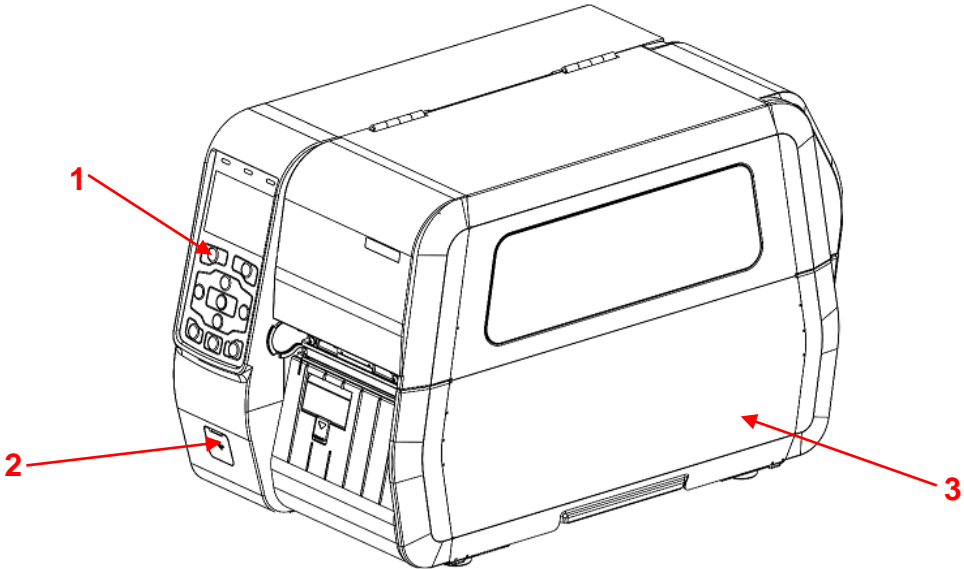

1	Control Panel	3	Media Cover
2	USB Host Port		

- Back

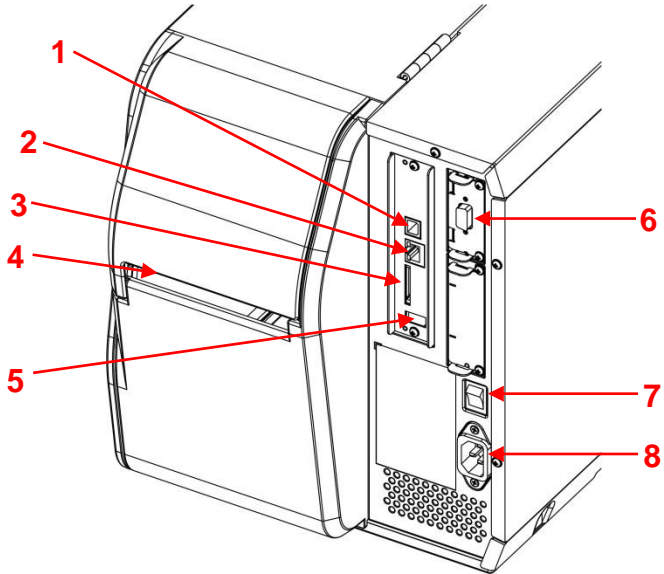

1	USB Port	5	USB Host Port
2	Ethernet Port	6	Serial(RS-232C) Port
3	SD Card Slot	7	Power Switch
4	Rear Access Slot(Media)	8	Power Connector

- Internal

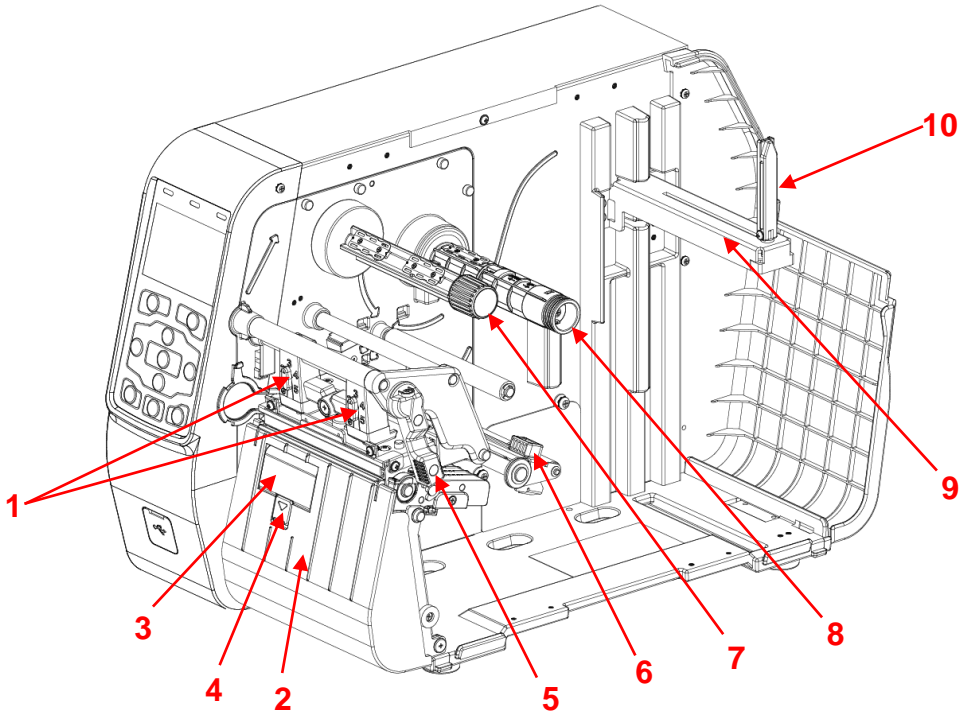

1	Print Head Pressure Adjustment	6	Rear Media Guide
2	Cover STD	7	Ribbon Take-up Spindle
3	Media Damper	8	Ribbon Supply Spindle
4	Media Damper Button	9	Media Holder
5	Print Head Lever	10	Media Fixing Guide

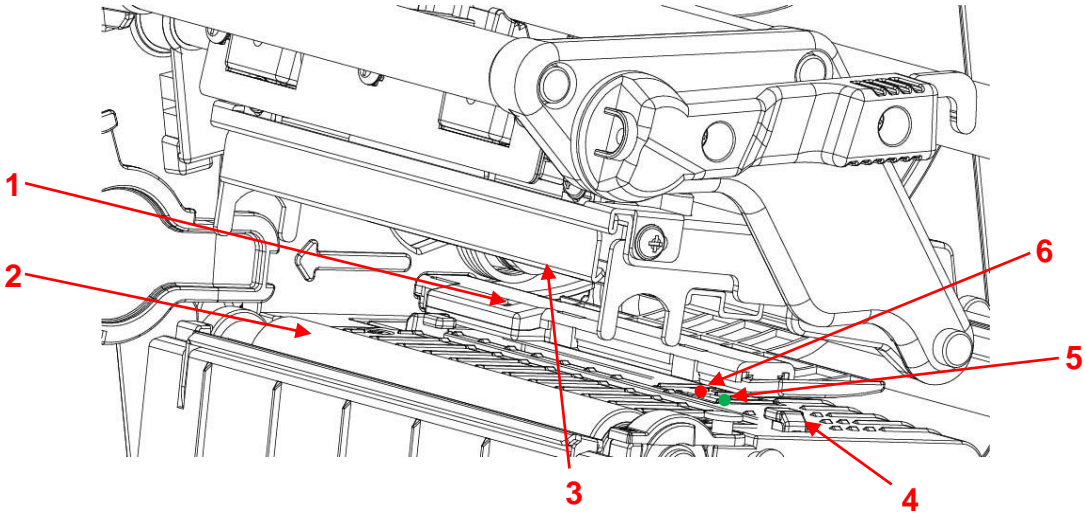

1	Ribbon Sensor	4	Front Media Guide
2	Platen Roller	5	Black Mark Sensor (Green LED)
3	Print Head	6	Gap & Notch Sensor (Red LED)

- Printer Option

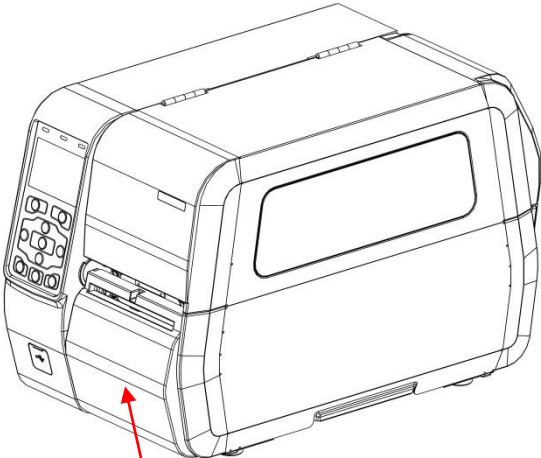

Auto Cutter

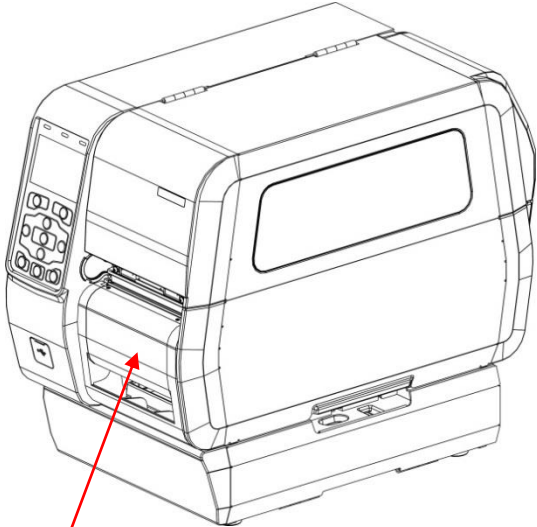

Rewinder

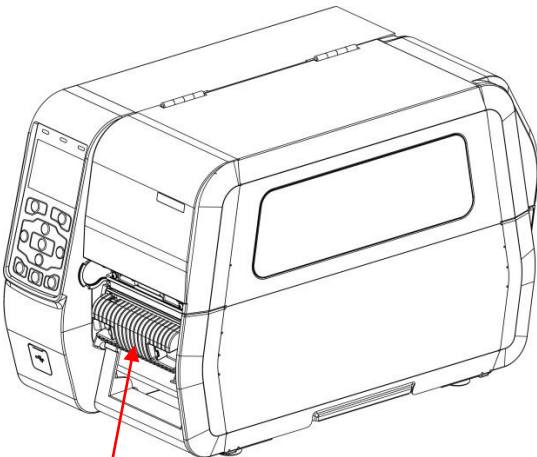

Peeler

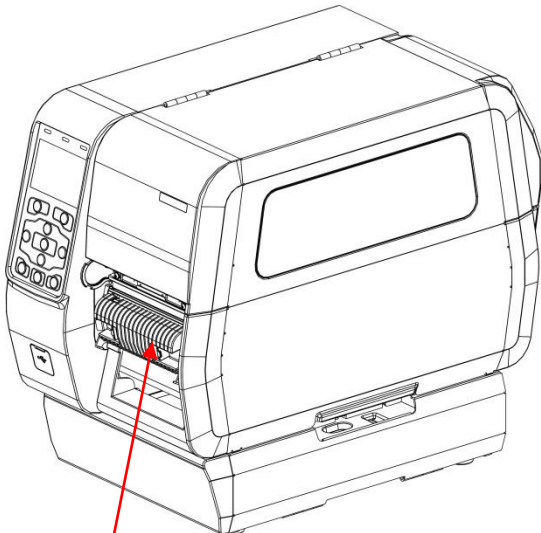

Peeler + Rewinder

2-2 Major Control Part Names(Standard Model)

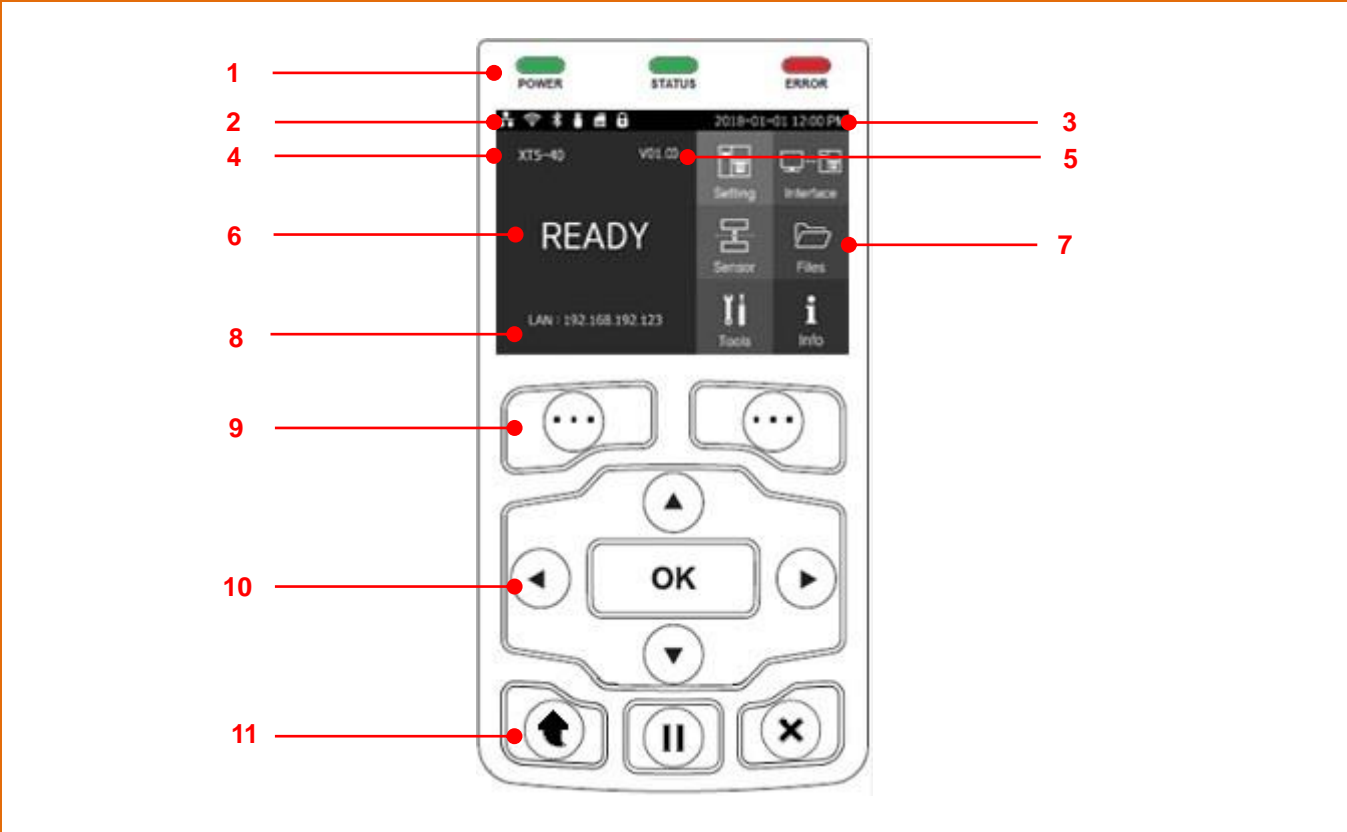

2-2-1 Control Panel











No	Description
1	Printer status LED
2	Interface status icon
3	Date, Time
4	Model name
5	Firmware version
6	Printer status
7	Main icon
8	Ethernet IP, WLAN IP
9	Function button
10	Direction button, Selection button
11	Printer operation button

2-2-2 Detailed Descriptions

2-2-2-1 Printer Status LED

List	Status	Explanation
 POWER	ON	Printer power on
	OFF	Printer power off
 STATUS	ON	Waiting for data reception
	BLINK	Receiving data
 ERROR	BLINK	Print error
	OFF	In normal operation

2-2-2-2 Interface Status Icon

List	Status	Explanation
	ON	Ethernet is connected
	OFF	Ethernet is not connected
	ON	Not connected to AP
	OFF	WLAN communication is not supported
	ON	Connected to AP, Strength: 4
	ON	Connected to AP, Strength: 3
	ON	Connected to AP, Strength: 2
	ON	Connected to AP, Strength: 1
	ON	Bluetooth is not connected to the host
	OFF	Bluetooth communication is not supported
	ON	Bluetooth is connected to the host
	ON	USB device is connected
	OFF	USB device is not connected
	ON	SD card is installed
	OFF	SD card is not installed
	ON	Password feature is enabled
	OFF	Password feature is disabled

2-2-2-3 Date, Time (RTC clock)

List	Explanation
YYYY-MM-DD	Date
12:00 AM/PM	Time



2-2-2-4 Model Name

List	Explanation
XT5-40	Model name







2-2-2-5 Firmware Version

List	Explanation
V01.00	Firmware version

2-2-2-6 Printer Status

List	Explanation
READY	Ready for print
STANDBY	<p>Standing by for user input</p> <ul style="list-style-type: none"> -  button: Switch to Print Standby Mode without feeding any media -  button: Feed one sheet of media to align the media position and switch to the Print Standby Mode
PRINTING	In printing
PAUSE	Printing pause
CANCEL	Canceled printing
F/W Downloading	Downloading firmware
PRINT HEAD OPEN	Print head is open
PRINT HEAD OVER TEMP	Print head has reached the maximum temperature
PRINT HEAD COLD TEMP	Print head has reached the minimum temperature
AUTO CUTTER JAM	Media is stuck in the auto cutter blade
MEADIA OUT	Media is not installed correctly
RIBBON OUT	Ribbon is not installed correctly
MEADIA JAM	Media is jammed and not printing normally
SENSING FAIL	Media is not recognized normally

2-2-2-7 Main Icons

List	Explanation
 Setting	Printer settings
 Interface	Interface settings
 Sensor	Sensor settings
 Files	File settings
 Tools	Additional and other functions settings
 Info	Providing printer information

2-2-2-8 Ethernet IP, WLAN IP

List	Explanation
LAN: 192.168.100.123	Ethernet IP
WLAN: 192.168.100.123	WLAN IP (displayed only when WLAN is supported)



2-2-2-9 Function Button

List	Explanation
	Used for selection, cancellation, storing, and deletion

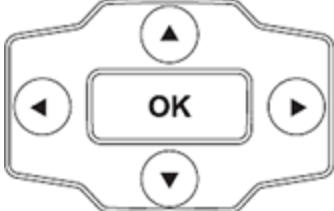
2-2-2-10 Direction Button, Selection Button

List	Explanation
	Used for menu selection

2-2-2-11 Printer Operation Button

List	Explanation
	Softly press and release the button to feed one label
	Press the button for 2 seconds during printing to pause printing
	Press the button for 2 seconds during printing to cancel printing

2-3 Major Control Part Names(Touch Screen Model)

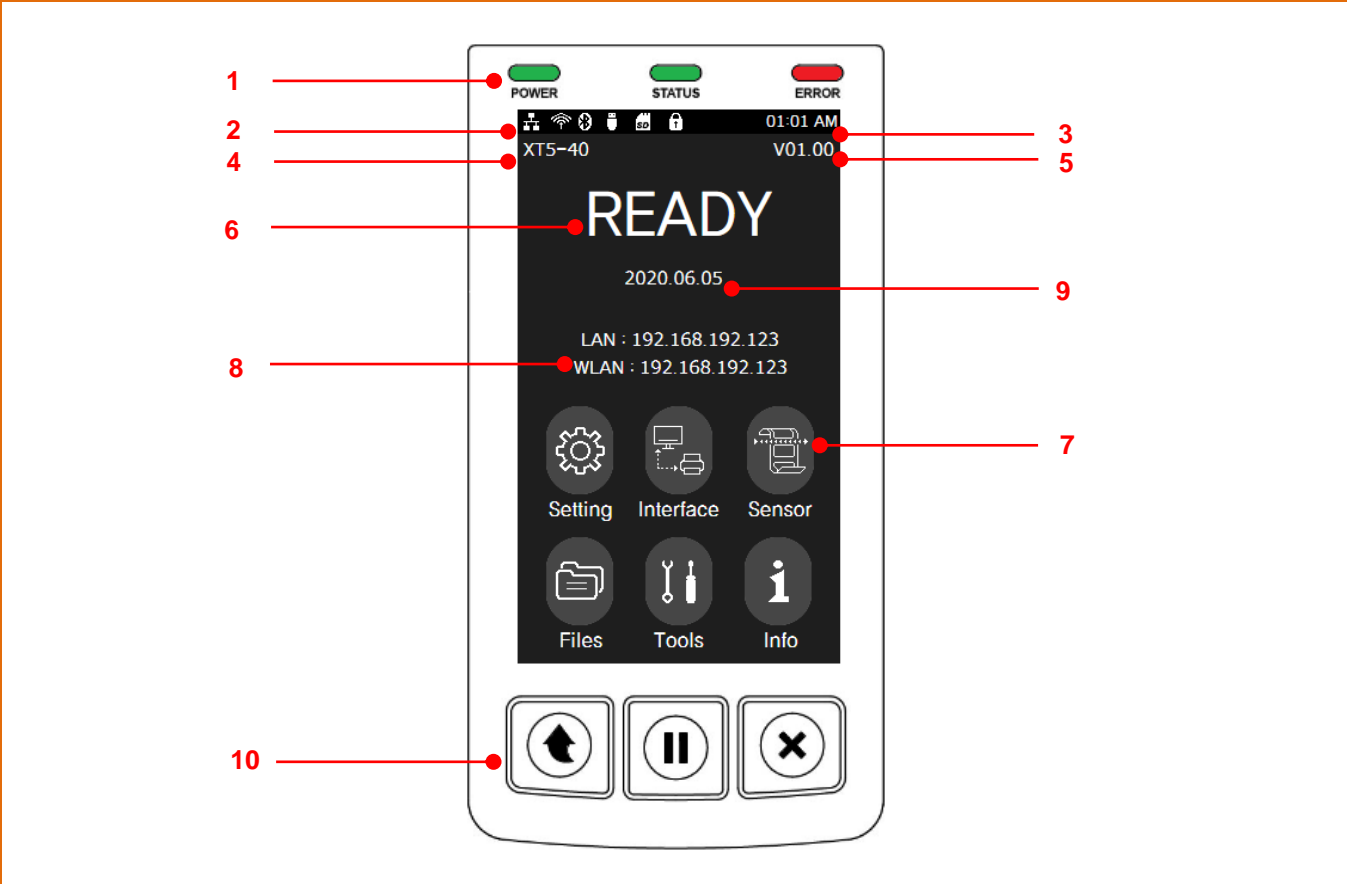

2-3-1 Control Panel













No	Description
1	Printer status LED
2	Interface status icon
3	Time
4	Model name
5	Firmware version
6	Printer status
7	Main icon
8	Ethernet IP, WLAN IP
9	Date
10	Printer operation button

2-3-2 Detailed Descriptions

2-3-2-1 Printer Status LED

List	Status	Explanation
 POWER	ON	Printer power on
	OFF	Printer power off
 STATUS	ON	Waiting for data reception
	BLINK	Receiving data
 ERROR	BLINK	Print error
	OFF	In normal operation

2-3-2-2 Interface Status Icon

List	Status	Explanation
	ON	Ethernet is connected
	OFF	Ethernet is not connected
	ON	Not connected to AP
	OFF	WLAN communication is not supported
	ON	Connected to AP, Strength: 4
	ON	Connected to AP, Strength: 3
	ON	Connected to AP, Strength: 2
	ON	Connected to AP, Strength: 1
	ON	Bluetooth is not connected to the host
	OFF	Bluetooth communication is not supported
	ON	Bluetooth is connected to the host
	ON	USB device is connected
	OFF	USB device is not connected
	ON	SD card is installed
	OFF	SD card is not installed
	ON	Password feature is enabled
	OFF	Password feature is disabled

2-3-2-3 Date, Time (RTC clock)

List	Explanation
YYYY-MM-DD	Date
12:00 AM/PM	Time



2-3-2-4 Model Name

List	Explanation
XT5-40	Model name







2-3-2-5 Firmware Version

List	Explanation
V01.00	Firmware version

2-3-2-6 Printer Status

List	Explanation
READY	Ready for print
STANDBY	<p>Standing by for user input</p> <ul style="list-style-type: none"> -  button: Switch to Print Standby Mode without feeding any media -  button: Feed one sheet of media to align the media position and switch to the Print Standby Mode
PRINTING	In printing
PAUSE	Printing pause
CANCEL	Canceled printing
F/W Downloading	Downloading firmware
PRINT HEAD OPEN	Print head is open
PRINT HEAD OVER TEMP	Print head has reached the maximum temperature
PRINT HEAD COLD TEMP	Print head has reached the minimum temperature
AUTO CUTTER JAM	Media is stuck in the auto cutter blade
MEADIA OUT	Media is not installed correctly
RIBBON OUT	Ribbon is not installed correctly
MEADIA JAM	Media is jammed and not printing normally
SENSING FAIL	Media is not recognized normally

2-3-2-7 Main Icons

List	Explanation
 SETTING	Printer settings
 INTERFACE	Interface settings
 SENSOR	Sensor settings
 FILE	File settings
 TOOL	Additional and other functions settings
 INFO	Providing printer information



2-3-2-8 Ethernet IP, WLAN IP

List	Explanation
LAN: 192.168.100.123	Ethernet IP
WLAN: 192.168.100.123	WLAN IP (displayed only when WLAN is supported)

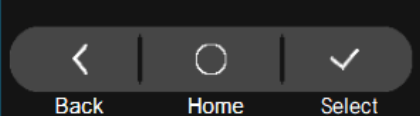
2-3-2-9 Function Button

List	Explanation
	Select, Cancel, Save, Delete, Move to main menu

2-3-2-10 Printer Operation Button

List	Explanation
	Press the button to feed one label
	Press the button for 2 seconds during printing to pause printing
	Press the button for 2 seconds during printing to cancel printing

3. Installation & Usage

3-1 Printer Installation Placings



- Install the printer in a location that meets the following conditions.
 - Allow sufficient space around the printer for proper ventilation.
 - Do not place objects close to the back or bottom of the printer, which may hinder the air circulation.
 - Install the printer on a flat and level surface.
 - Avoid humid environment.
 - Install in a place that does not exceed the protocol standard of the wireless communication or the specified maximum distance.
 - For stable wireless communication, install in a place where there is no physical obstacle (wall, object, etc.).

3-2 Power Connection

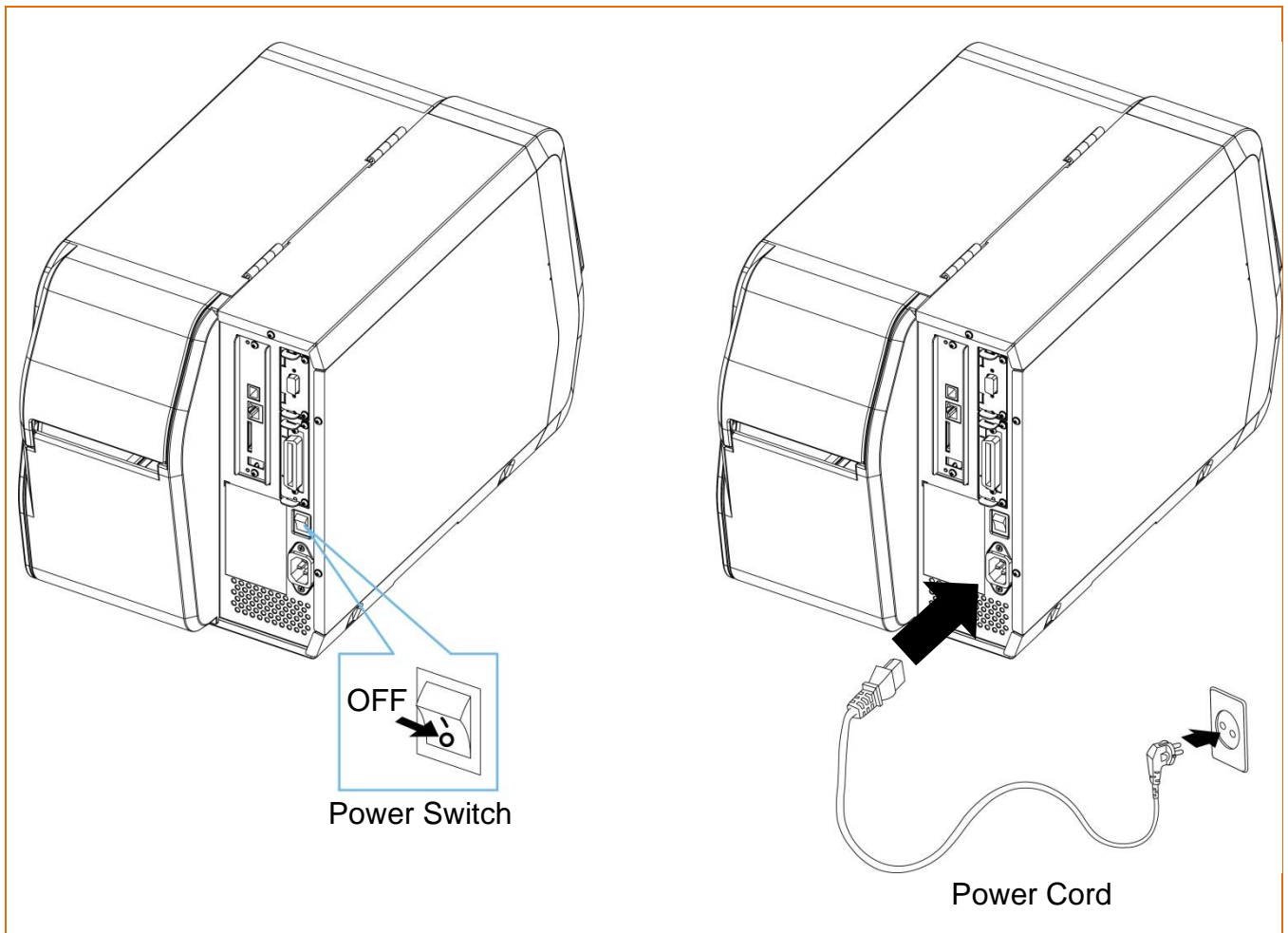

- Connect power to the printer as shown below.



- 1) Turn off the printer power switch.
- 2) Connect the power cord to the printer.
- 3) Connect the power cord to a power source/outlet.

 Caution	For the safety of people and equipment, please use the appropriate power cord for your country or region.
 Warning	<ul style="list-style-type: none">- Be sure to turn off the printer before connecting the power cord to the printer. This can cause serious electrical damage and bodily injury.- Do not operate the printer and power supply in a humid environment. This can cause serious electrical damage and bodily injury.- Do not connect an input voltage beyond the specifications of the power supply. This may result in product damage and fire.

3-3 Interface

 Note	<p>Shielded cables must be used to prevent radiation and reception of electrical noise. Use the shortest possible communication cable to minimize the detection of electrical noise in the cable.</p> <ul style="list-style-type: none">- Serial(RS-232C) Cable (1.8m or less recommended)- Parallel(IEEE1284) Cable (1.8m or less with ferrite core recommended)- USB B-Type Cable (1.8m or less recommended)- LAN(Ethernet) Cable (3m or less, CAT-5 or higher UTP Cable)
 Caution	<ul style="list-style-type: none">- Connecting unshielded communication cables is in violation of EMC standards. Use the cable approved by us.- Do not bundle the communication cable with objects that may cause electrical noise and interference. The printer may be damaged.
 Warning	<p>After turning off the power switch of printer, connect and disconnect the communication cable. This can cause serious electrical damage and bodily injury.</p>

3-3-1 Standard Interface

This printer can use the following types of communication.

- LAN (Ethernet) Cable / USB B-Type Cable / Serial (RS-232C) Cable

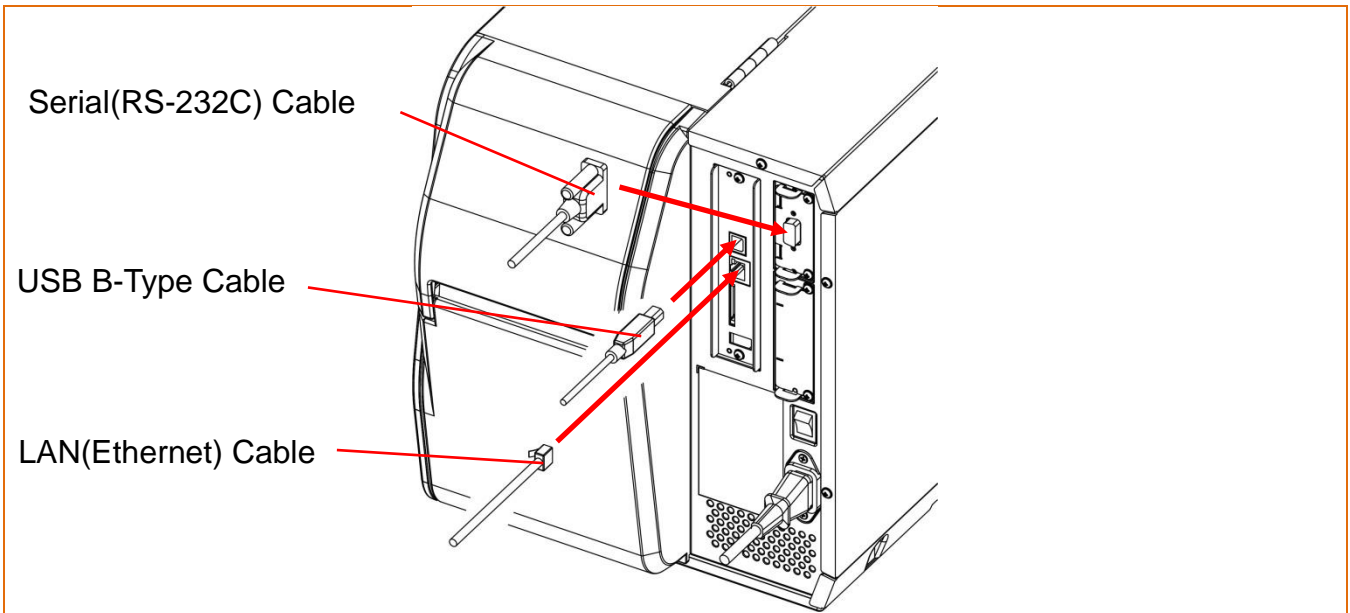

- 1) Turn off the power switch.
- 2) Connect the communication cable to the printer communication port to be used.
 - Connect the LAN(Ethernet) cable to the Ethernet port.
 - Connect the USB B-Type cable to the USB port.
 - Connect Serial(RS-232C) cable to the serial port and tighten both screws.



Caution

Be aware that the product's electronic components may be damaged due to discharging of electrostatic energy that accumulates on the surface of the body or other objects.

3-3-2 Option Interface

This printer can use the following types of communication.

- WLAN / Bluetooth / Parallel(IEEE1284) Cable

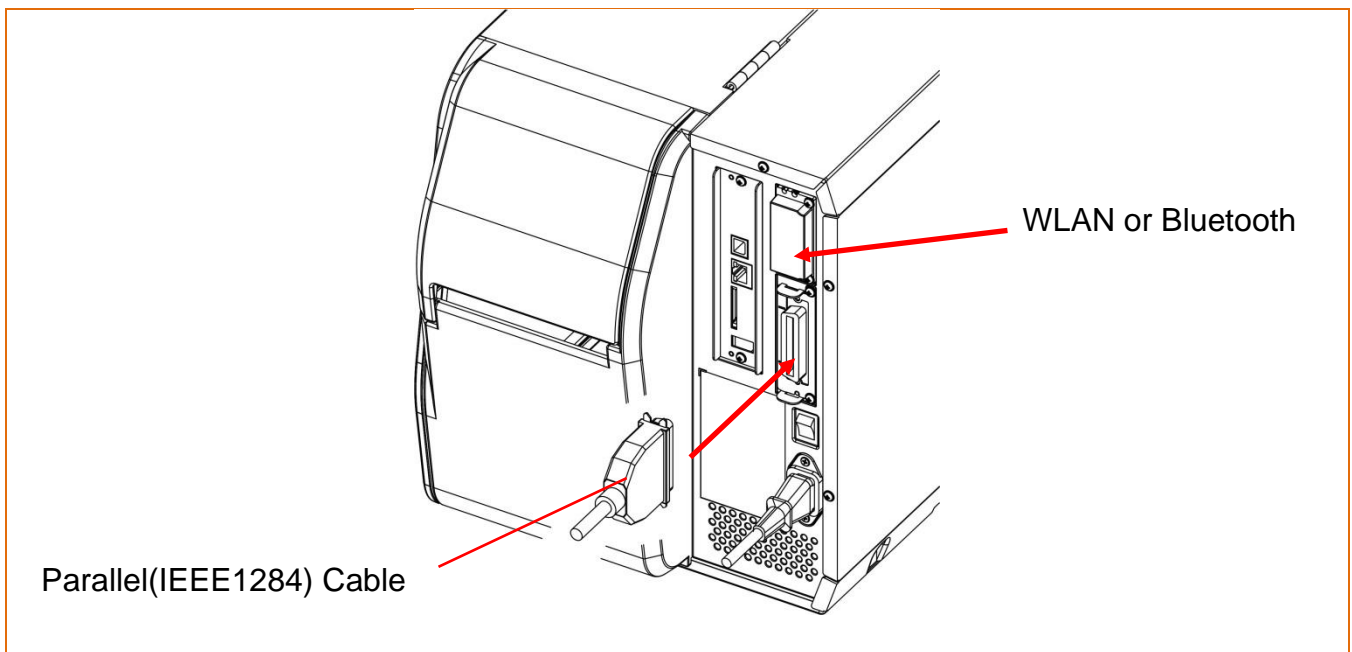

- 1) Turn off the power switch.
- 2) Connect the communication cable to the printer communication port to be used.
 - Connect Parallel(IEEE1284) Cable to parallel port and fasten both clips.
 - Wireless interface does not require a separate cable connection



Be aware that the product's electronic components may be damaged due to discharging of electrostatic energy that accumulates on the surface of the body or other objects.

3-4 Media Installation

3-4-1 Media Installation Method of Standard Model

For standard models, install media in the following ways:

- 1) Open the media cover.

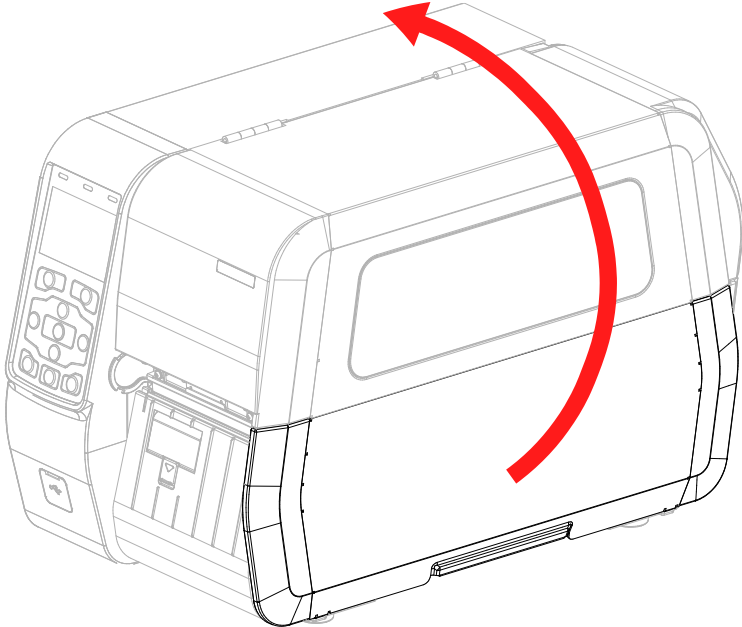

- 2) Open the print head lever. Flip down the media fixing guide and place the media in the media holder with print side up.

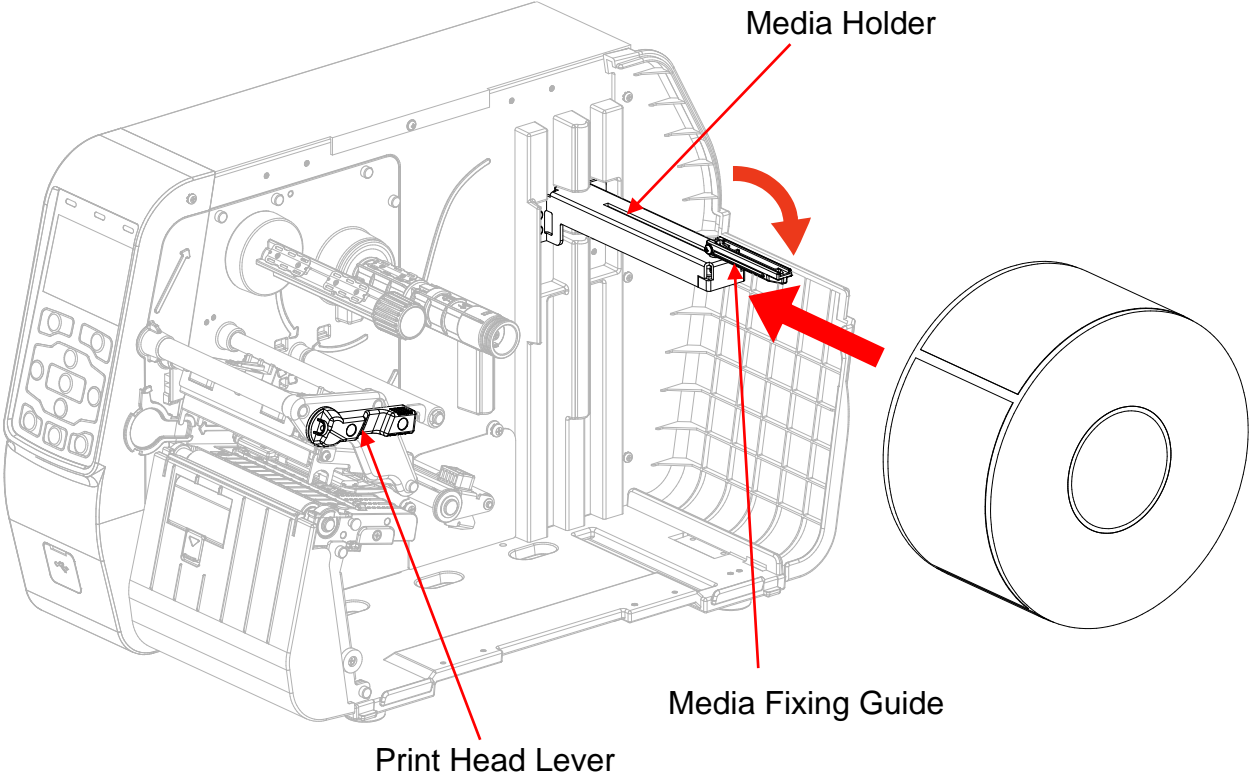

- 3) After flip up the media fixing guide, push the holder so that it is close to the media.
Push the front and rear media guides to the right.

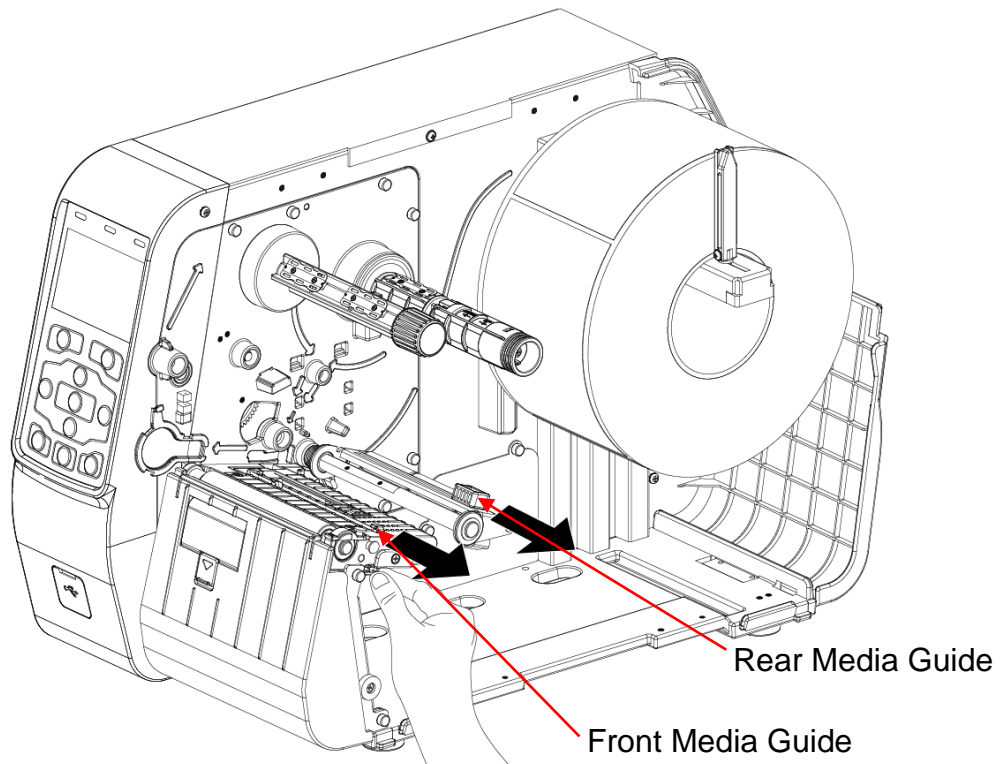

- 4) After inserting the media into the fixing guides, adjust the front and rear media guides to the media width.

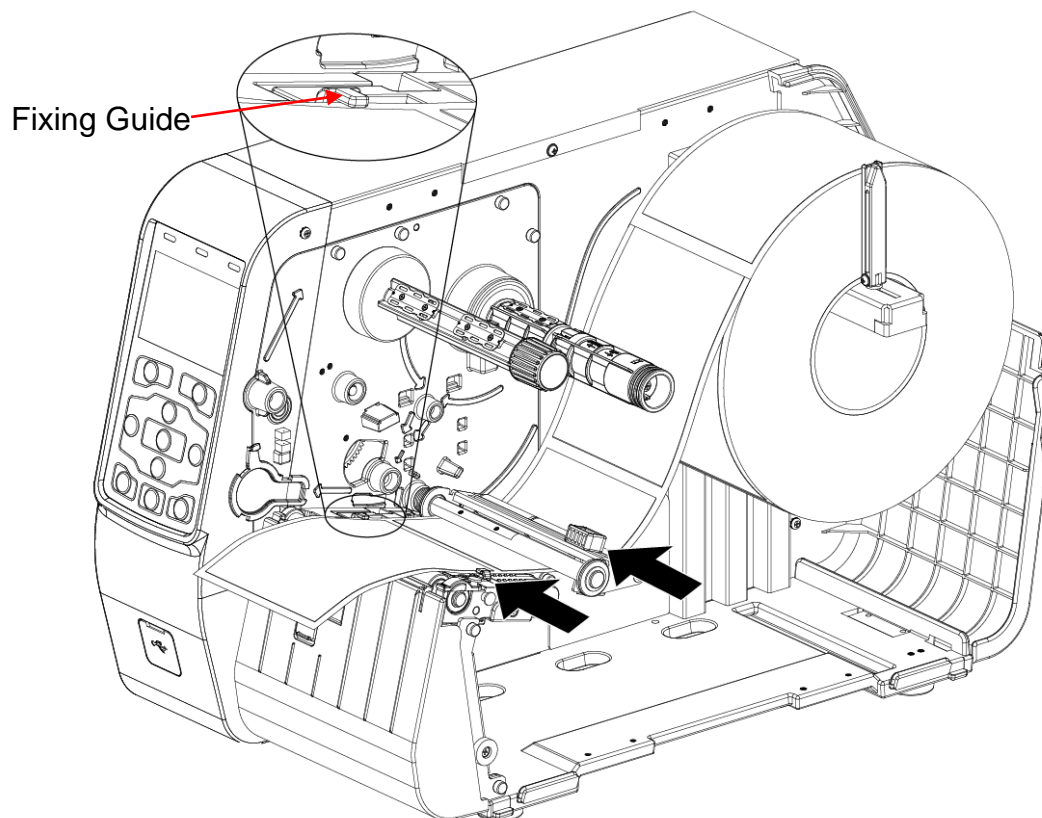

XT5-40 Series

- 5) Please make sure the sensor position where media gap/black mark will pass through for sensing. Sensor(gap & notch sensor, black mark sensor) can be moved by the sensor lever. Check the sensor position with LED color.

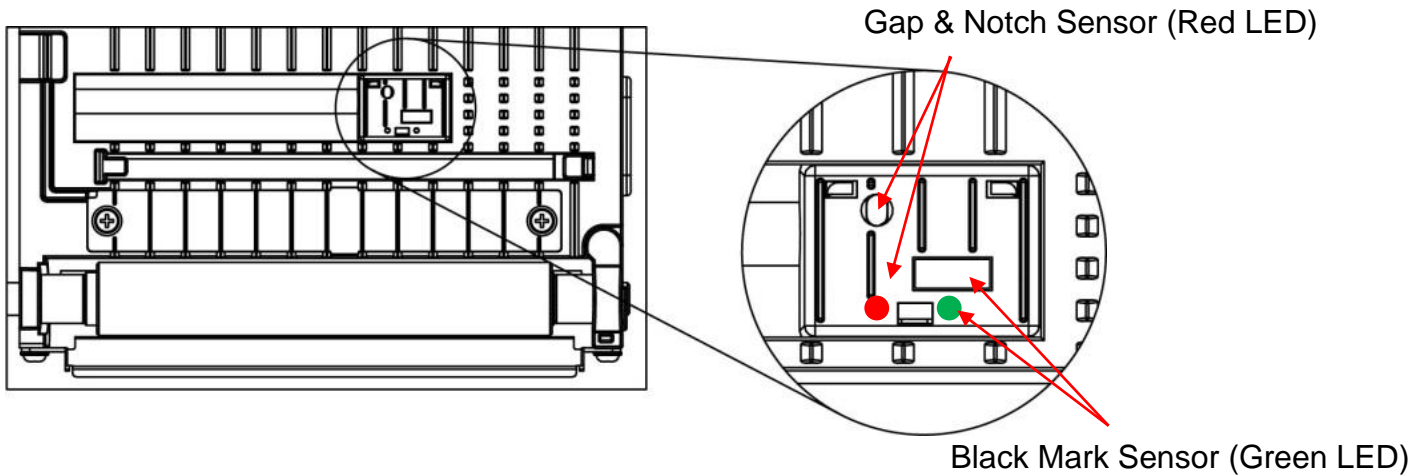

- 6) Close the print head lever and media cover.



Caution

- When opening or closing the cover, be careful not to pinch your fingers.
- Do not open the print head levers while the printer is printing. The printer may be damaged.
- Change the media when the printer is not receiving data, or data may be lost.



Warning

While the printer is operating, the print head gets very hot, so turn off the power and let it cool down completely. The hot print head can cause serious burns.

3-4-2 Media Installation Method of Auto Cutter (optional) Model

Use the autocutter to cut the printed media.

For Auto Cutter Model, install media in the following ways:

- 1) Refer to '3-4-1 Media Installation Method of Standard Model' to install media, adjust media guide and sensor position.
- 2) Install the media through the auto cutter as shown in the figure.

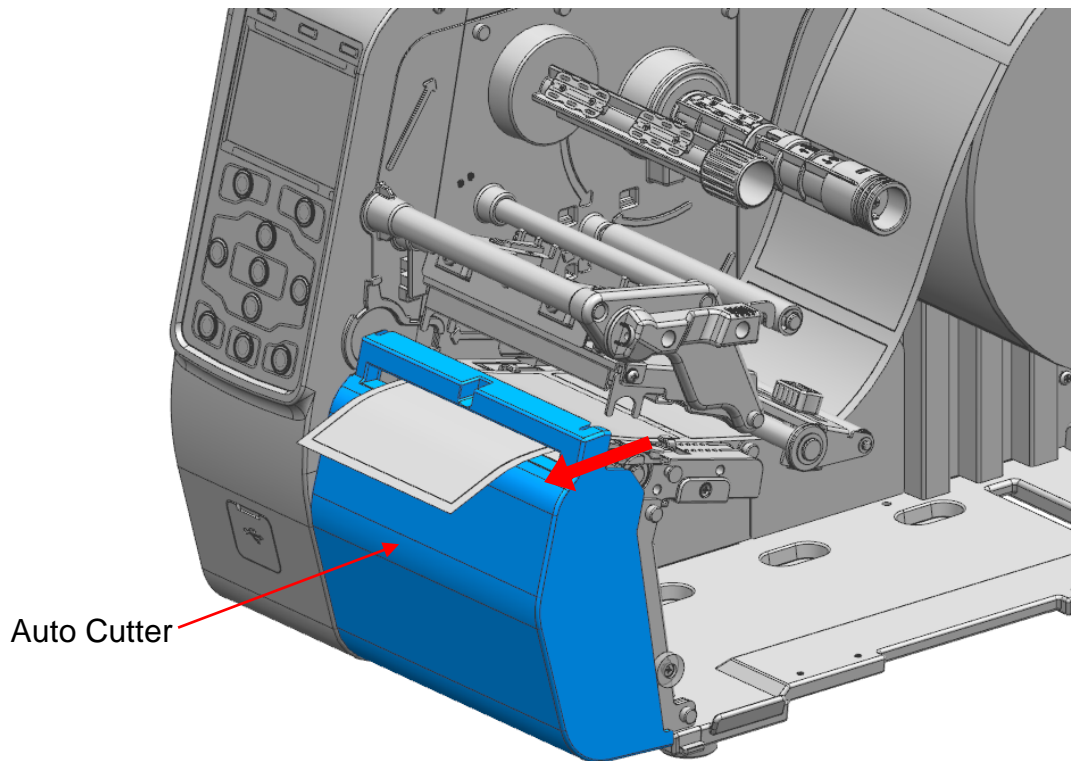

- 3) Close the print head lever and media cover.

⚠ Caution

- When opening or closing the cover, be careful not to pinch your fingers.
- Do not open the print head levers while the printer is printing. The printer may be damaged.
- Change the media when the printer is not receiving data, or data may be lost.

⚠ Warning

- **Never insert objects or fingers while performing the cutting function. This can cause serious bodily injury.**
- **Be careful not to touch the cutter blade with your hand. There may be a risk of personal injury.**
- **While the printer is operating, the print head gets very hot, so turn off the power and let it cool down completely. The hot print head can cause serious burns.**

3-4-3 Media Installation Method of Rewinder(optional) Model

Use the rewriter to automatically rewind the printed media.
When shipped from the factory, the rewriter is attached.
For Rewinder Model, install media in the following ways:

•3-4-3-1 Media Installation Method - Using Media Core.

- 1) Refer to '3-4-1 Media Installation Method of Standard Model' to install media, adjust media guide and sensor position.
- 2) Open the rewriter cover.

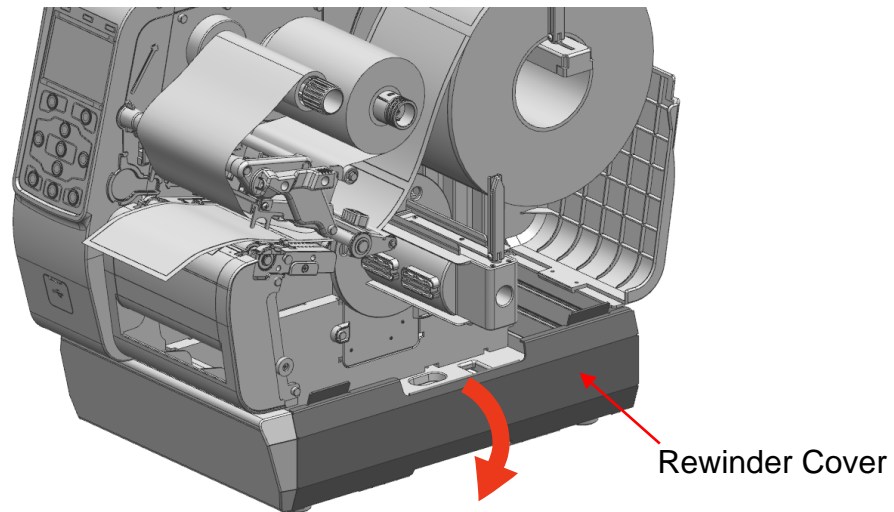

- 3) After flip down the rewriter fixing guide, install a 3inch media core on the rewriter holder.

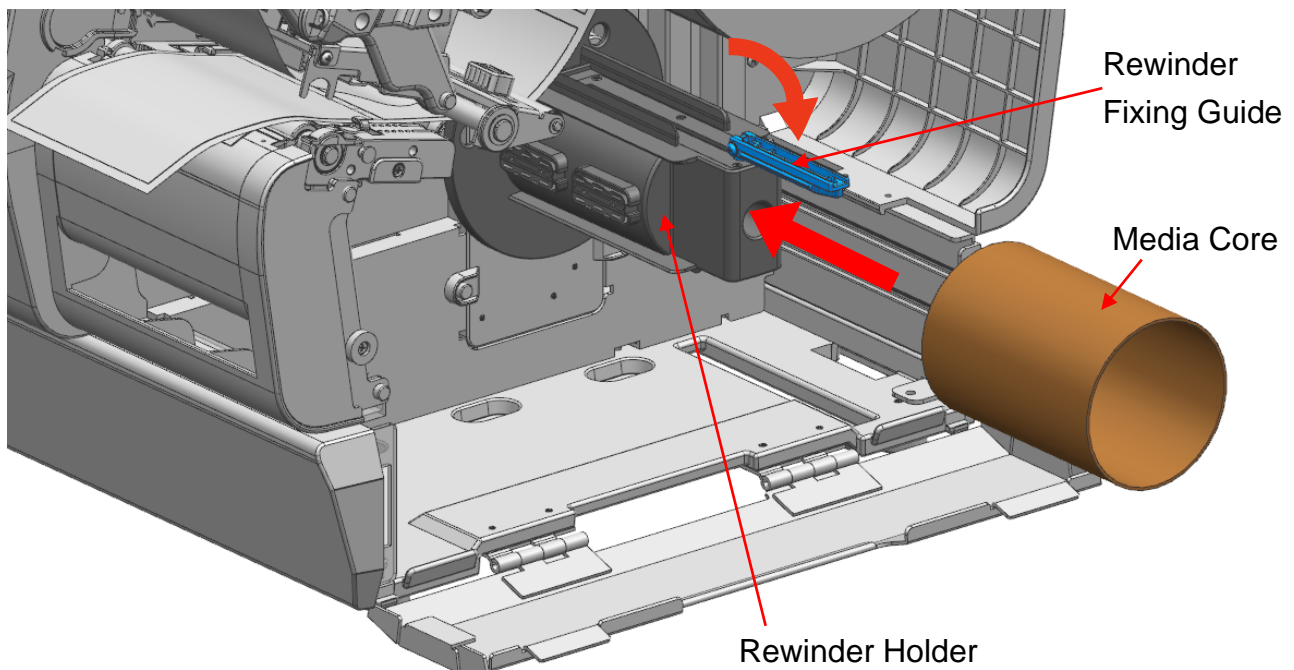

4) After installing the media in the same way as the picture, attach the media to the media core using tape.

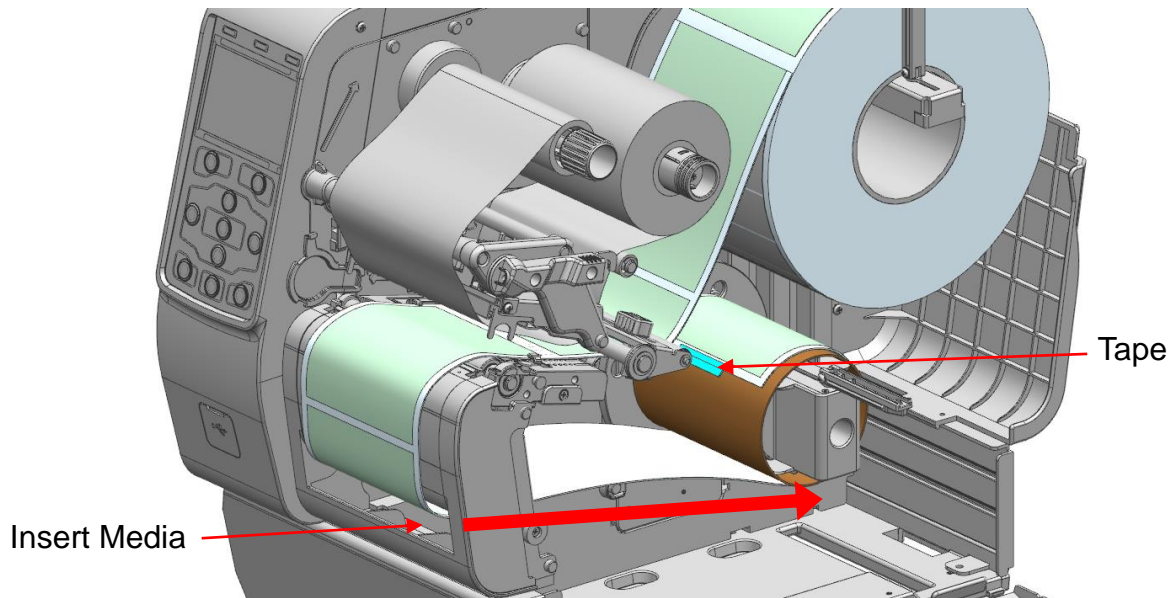

5) After flip up the rewriter fixing guide, push it close to the media.

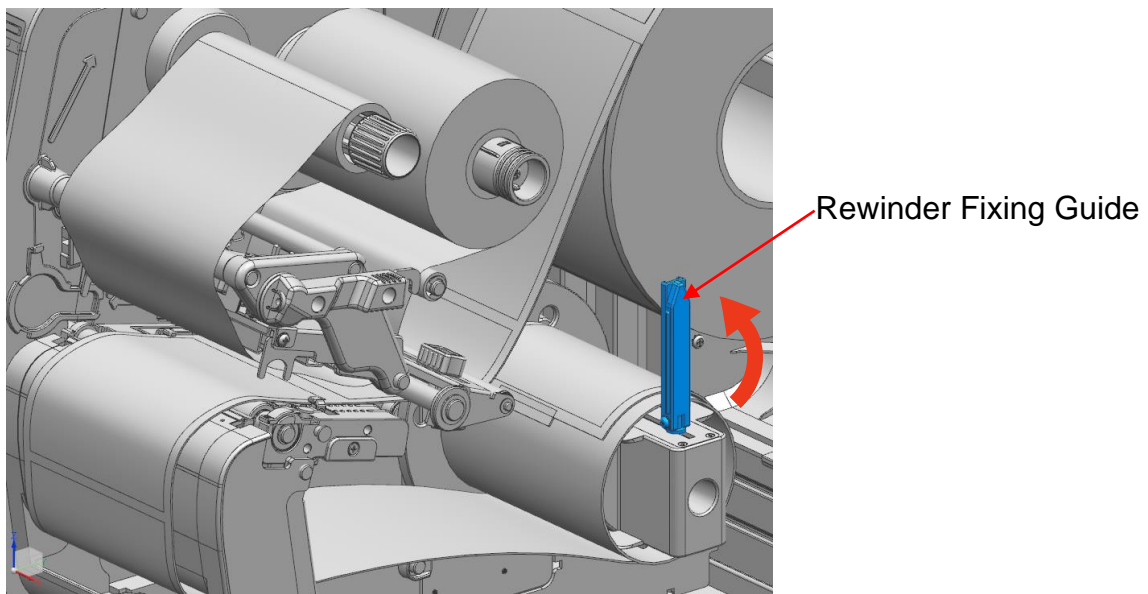

6) Close the print head lever, the rewriter cover, and the media cover.

⚠ Caution

- When opening or closing the cover, be careful not to pinch your fingers.
- Do not open the print head levers while the printer is printing. The printer may be damaged.
- Change the media when the printer is not receiving data, or data may be lost.

⚠ Warning

While the printer is operating, the print head gets very hot, so turn off the power and let it cool down completely. The hot print head can cause serious burns.

•3-4-3-2 Media Installation(Removal) Method - Not Using Media Core

•Media Installation Method

- 1) Refer to '3-4-1 Media Installation Method of Standard Model' to install media, adjust media guide and sensor position.
- 2) Open the rewinder cover.

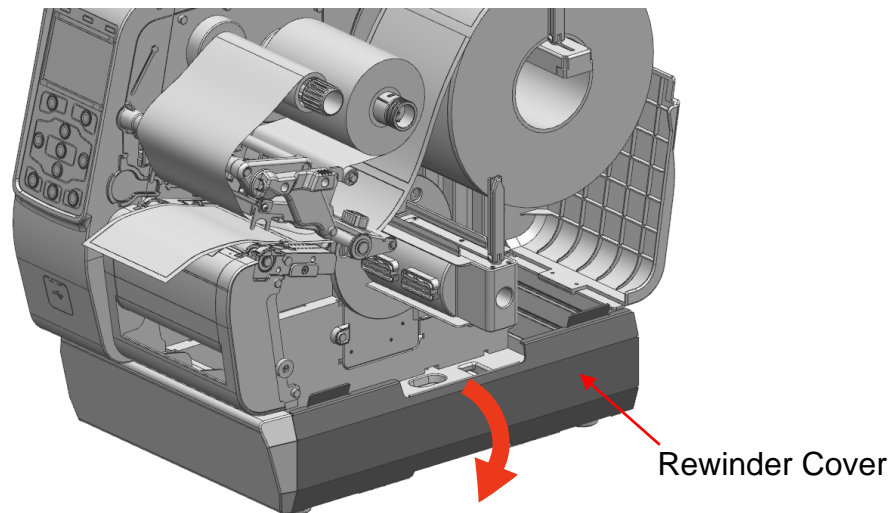

- 3) After installing the media in the same way as the picture, fix the media at rewriter media guide.

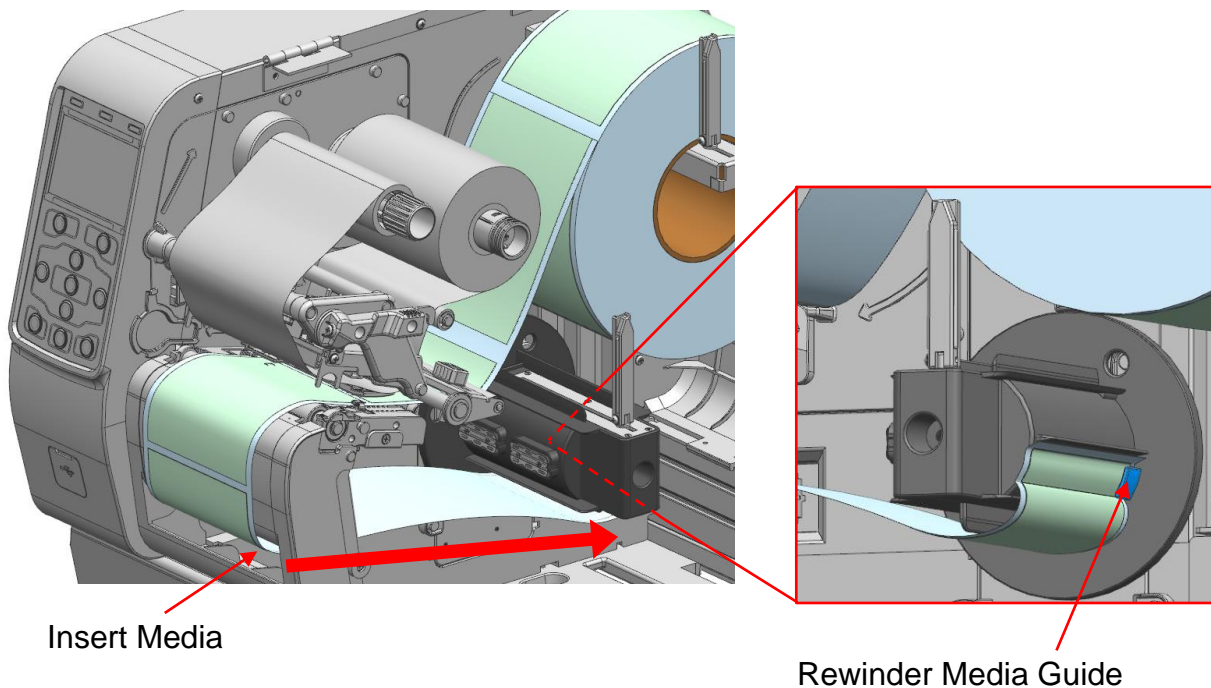

4) Adjust the rewriter fixing guides to the media width.

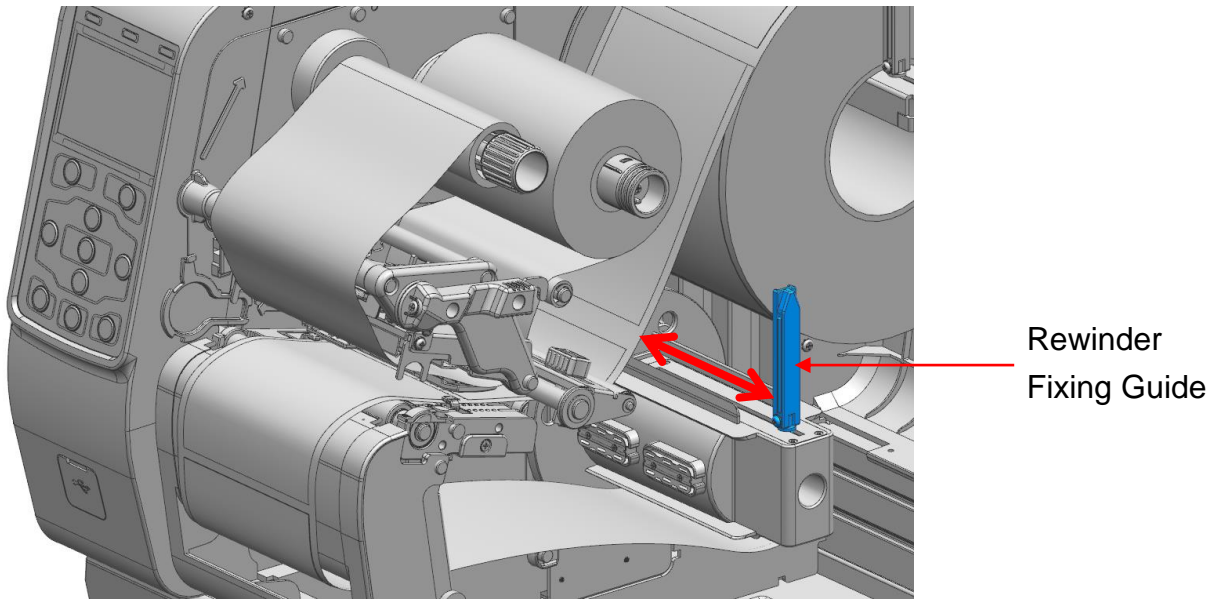

5) Close the print head lever, the rewriter cover, and the media cover.

Media Removal Method

1) Open the media cover, the rewriter cover and the print head lever.

2) Rotate the rewriter media holder counter-clockwise to collect the media.

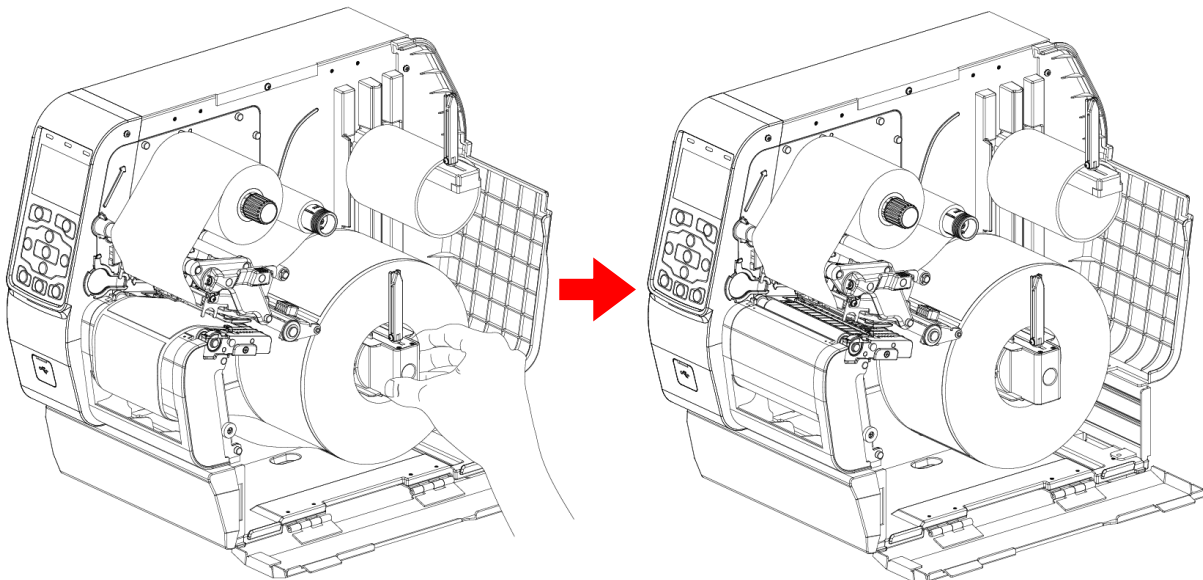

3) After flip down the rewriter fixing guide, push it inside.

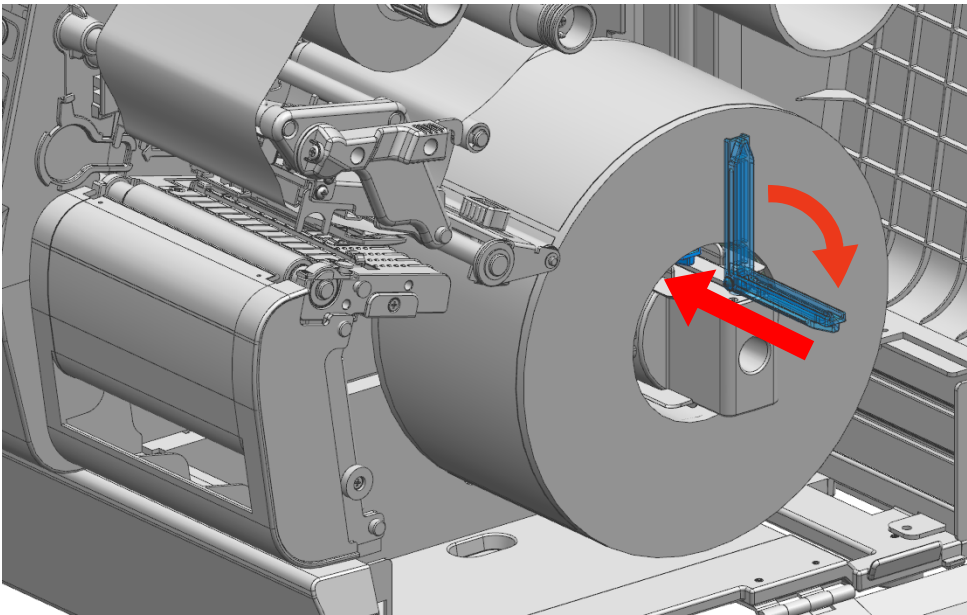

4) Remove the media.

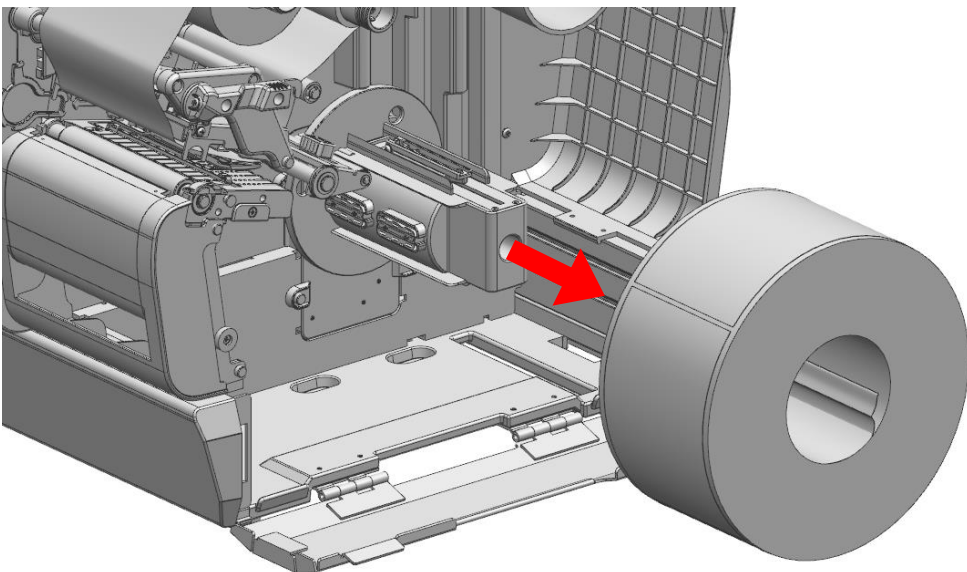

Note

- When removing the media, make sure it is not damaged by other parts.



Caution

- When opening or closing the cover, be careful not to pinch your fingers.

- Do not open the print head levers while the printer is printing. The printer may be damaged.

- Change the media when the printer is not receiving data, or data may be lost.



Warning

While the printer is operating, the print head gets very hot, so turn off the power and let it cool down completely. The hot print head can cause serious burns.

3-4-4 Media Installation Method of Peeler (optional) Model

Use a peeler to automatically separate the printed media from the liner.
When shipped from the factory, the peeler is attached.
For Peeler Model, install media in the following ways:

- 1) Refer to '3-4-1 Media Installation Method of Standard Model' to install media, adjust media guide and sensor position.
- 2) Press the left and right peeler levers to open the peeler cover.

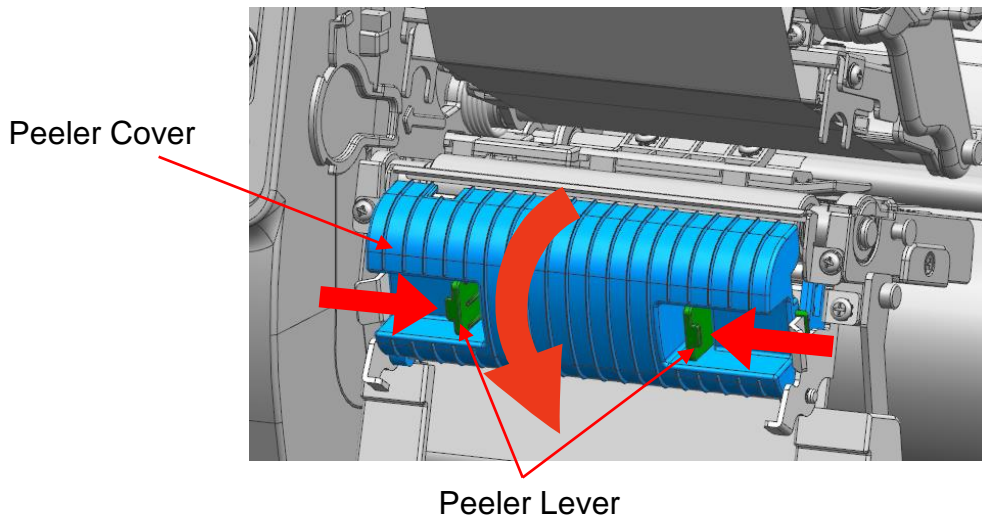

- 3) Move the peeler switch to ON. Please make sure that the LED has turned on.

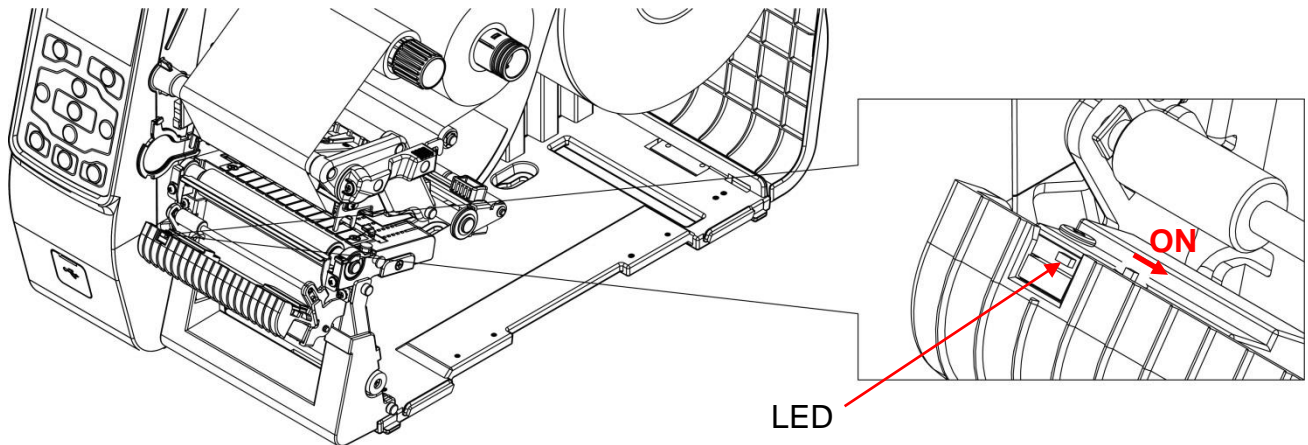

4) Remove several sheets of label media and insert liner as in the picture.

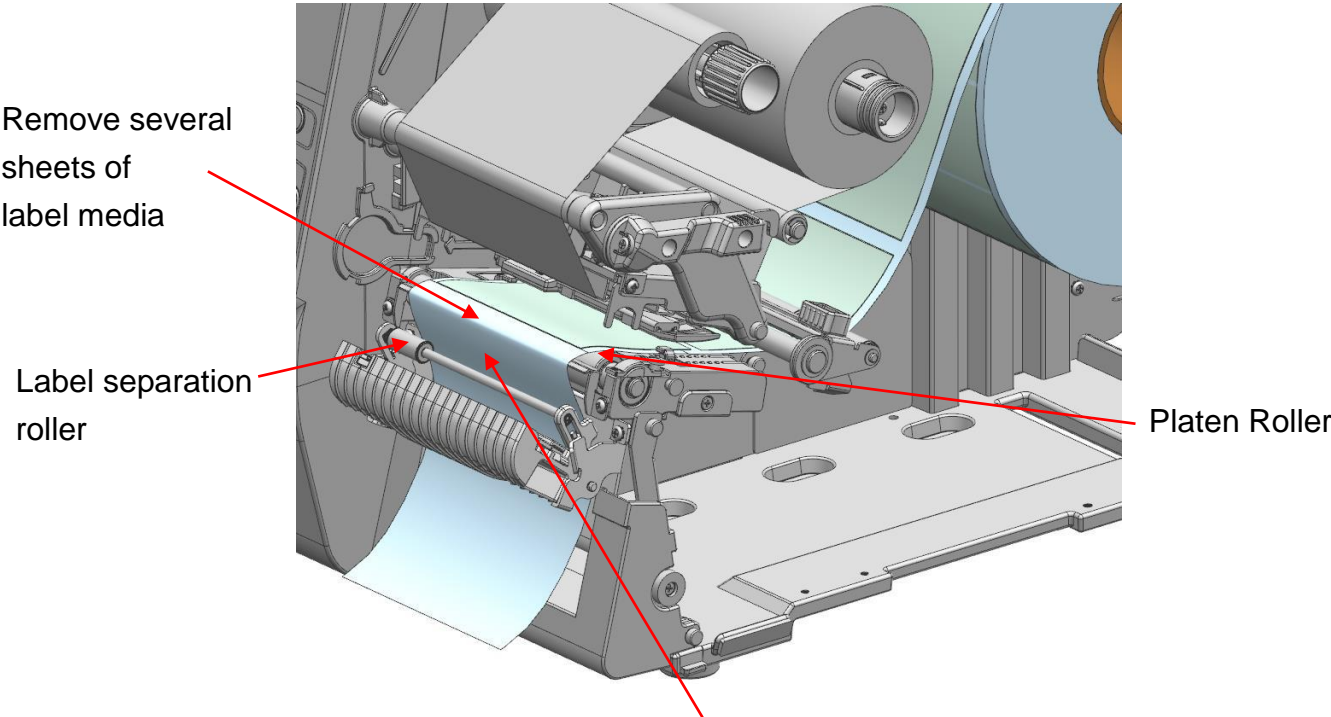

Insert media between platen roller and label separation roller

5) Close the peeler cover until it clicks.

(O)

(X)

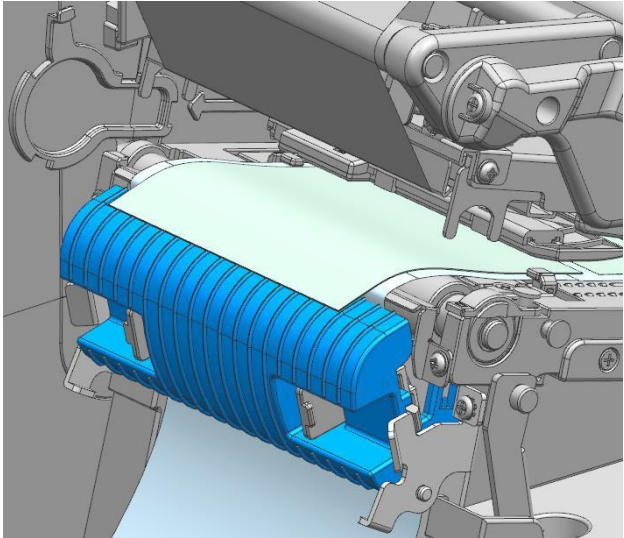
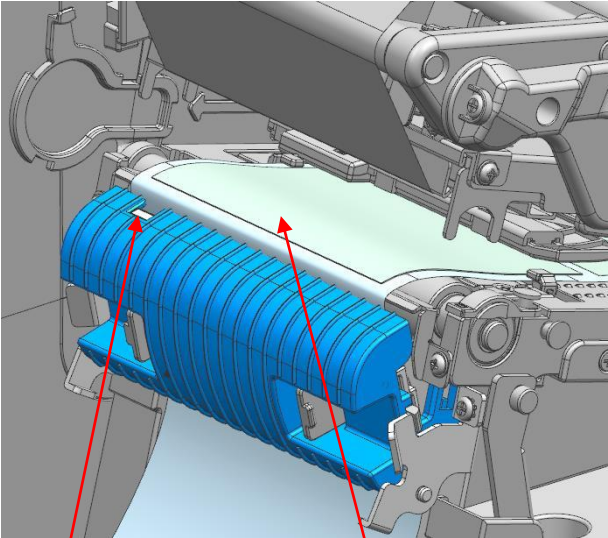

Be careful that the media does not cover the peeler sensor

6) Close the print head lever, the rewriter cover, and the media cover.



Caution

- When opening or closing the cover, be careful not to pinch your fingers.
- Do not open the print head levers while the printer is printing. The printer may be damaged.
- Change the media when the printer is not receiving data, or data may be lost.
- The peeler function is only available for label media.
- When the peeler is switched on, the next label will not be printed unless the printed label is removed from the peeler.
- When the peeler is switched off, the peeler does not work.



Warning

**While the printer is operating, the print head gets very hot, so turn off the power and let it cool down completely.
The hot print head can cause serious burns.**

3-4-5 Media Installation Method of Peeler + Rewinder(optional) Model

Use the 'peeler + rewinder' to automatically separate the printed media from the liner and rewind the printed media.

When shipped from the factory, the peeler is attached.

For 'Peeler + Rewinder Model', install media in the following ways:

• 3-4-5-1 Media Installation Method - Using Media Core.

- 1) Refer to '3-4-1 Media Installation Method of Standard Model' to install media, adjust media guide and sensor position.
- 2) Open the rewinder cover.
After flip down the rewinder fixing guide, install a 3inch media core in the rewinder holder.
(Please refer to 3-4-3 Media Installation Method of Rewinder Model)
- 3) Press the left and right peeler levers to open the peeler cover.

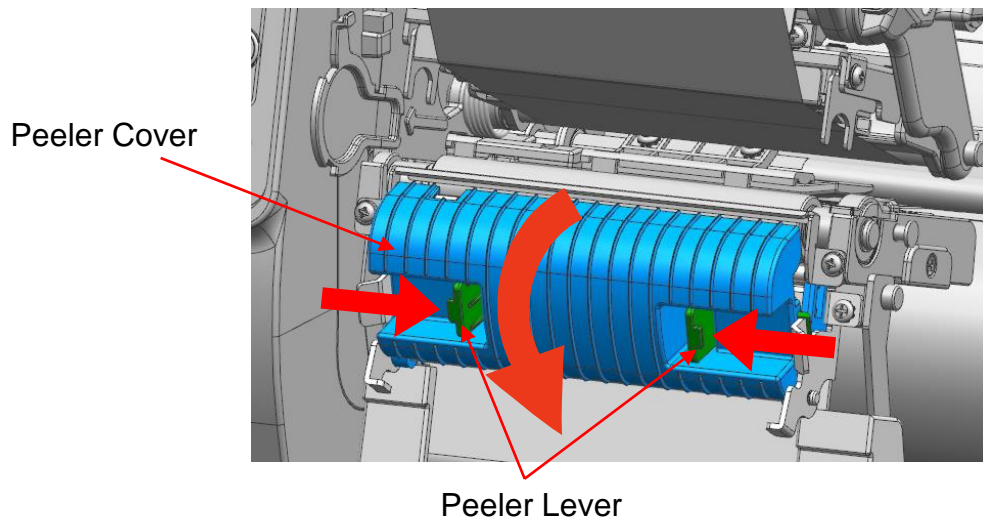

- 4) Move the peeler switch to ON. Please make sure that the LED has turned on.

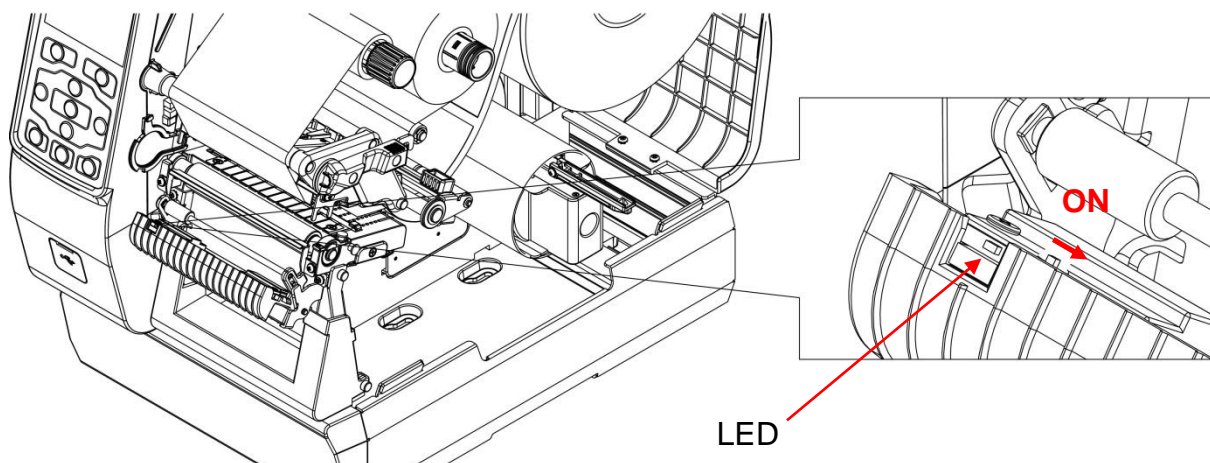

5) Remove several sheets of label media and insert liner as in the picture.

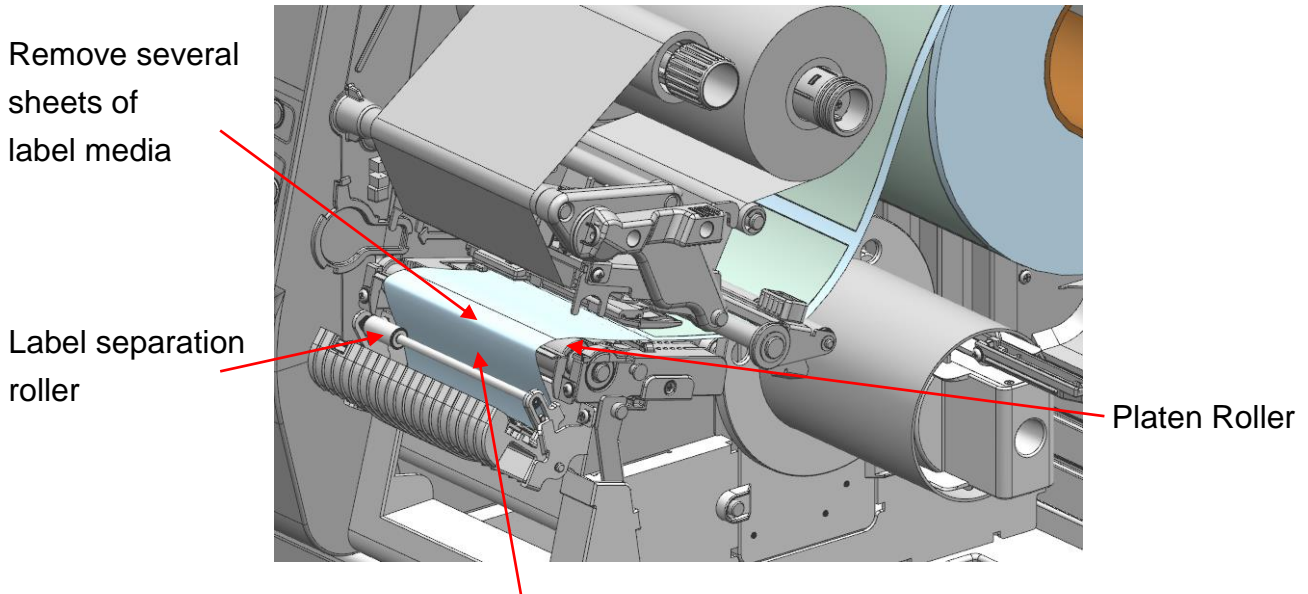

Insert media between platen roller and label separation roller

6) After installing the media in the same way as the picture, attach the media to the media core using tape.

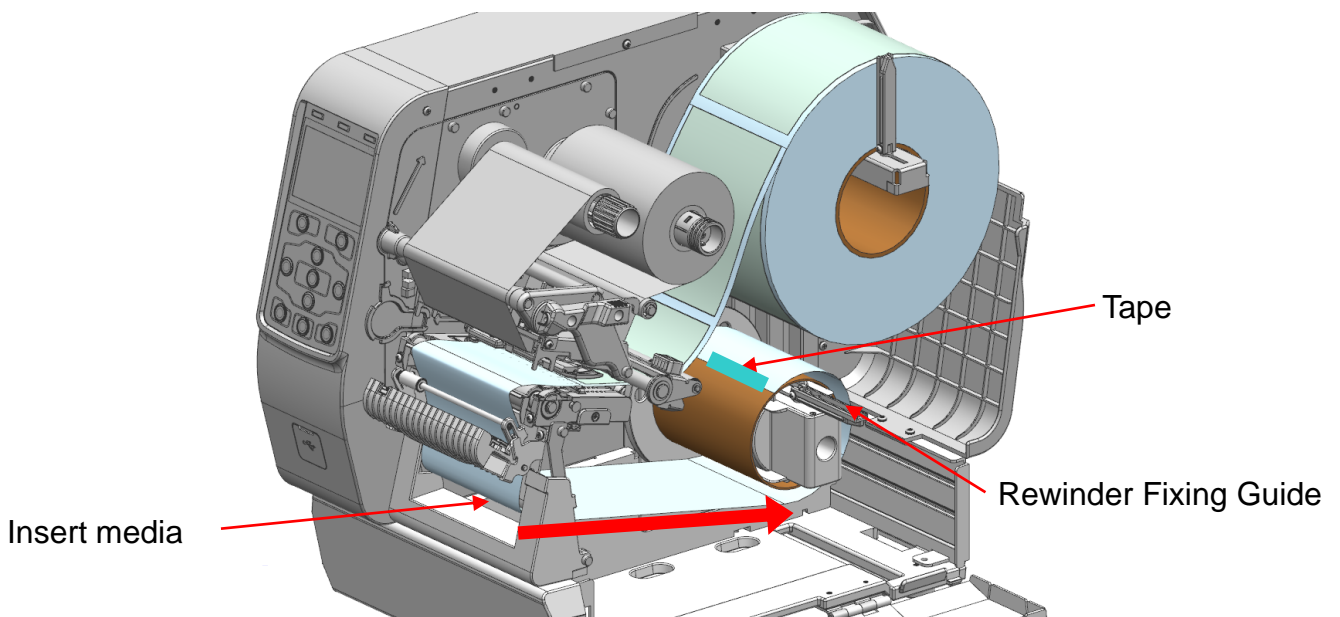

7) Raise the rewriter fixing guide, and then push it close to the media.

8) Close the peeler cover until it clicks.

(O)

(X)

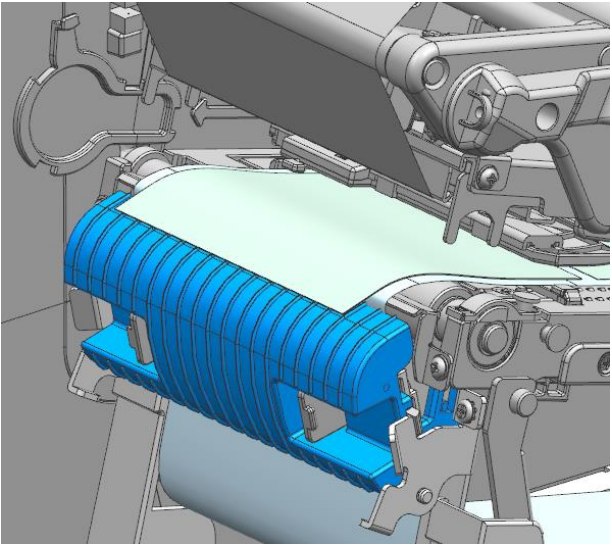
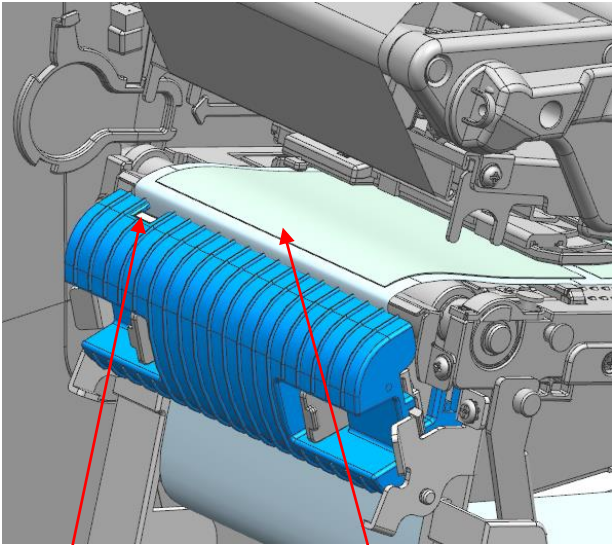

Peeler Sensor Be careful that the media does not cover the peeler sensor

9) Close the print head lever, the rewinder cover, and the media cover.

•3-4-5-2 Media Installation(Removal) Method - Not Using Media Core.

•Media Installation Method

- 1) Refer to '3-4-1 Media Installation Method of Standard Model' to install media, adjust media guide and sensor position.
- 2) Open the rewinder cover.
After flip down the rewinder fixing guide, push it inside.
(Please refer to 3-4-3 Media Installation Method of Rewinder Model)
- 3) Press the left and right peeler levers to open the peeler cover.

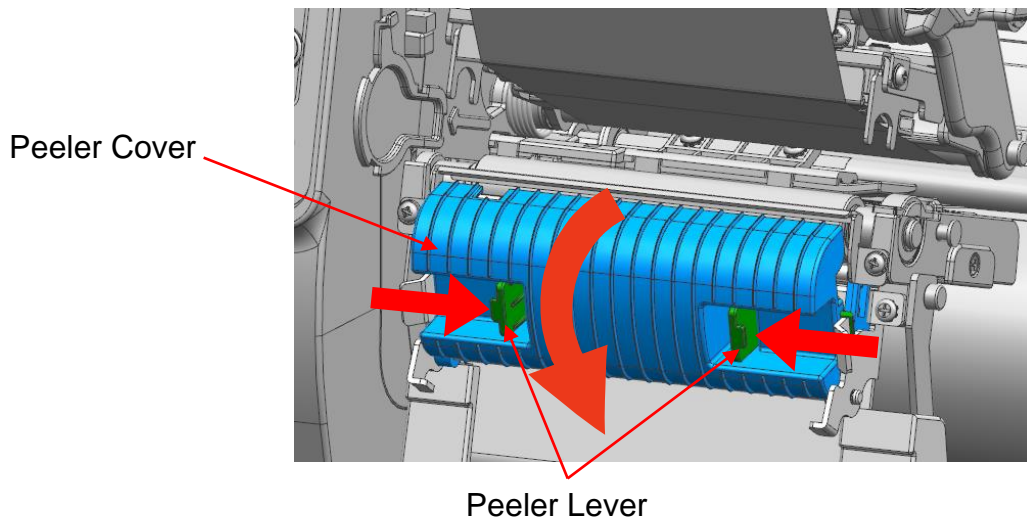

- 4) Move the peeler switch to ON. Please make sure that the LED has turned on.

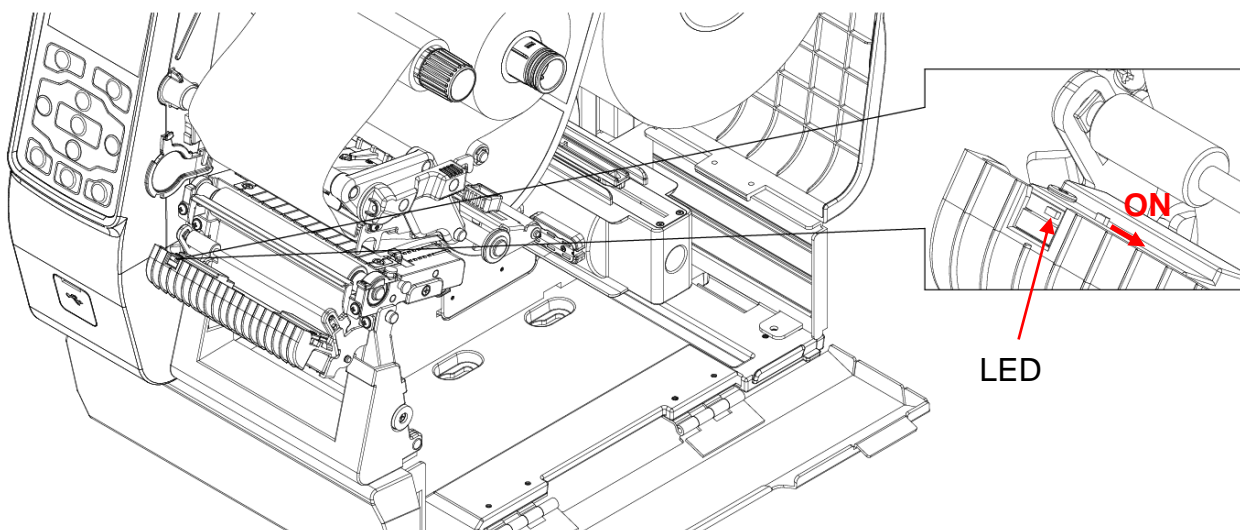

5) Remove several sheets of label media and insert liner as in the picture.

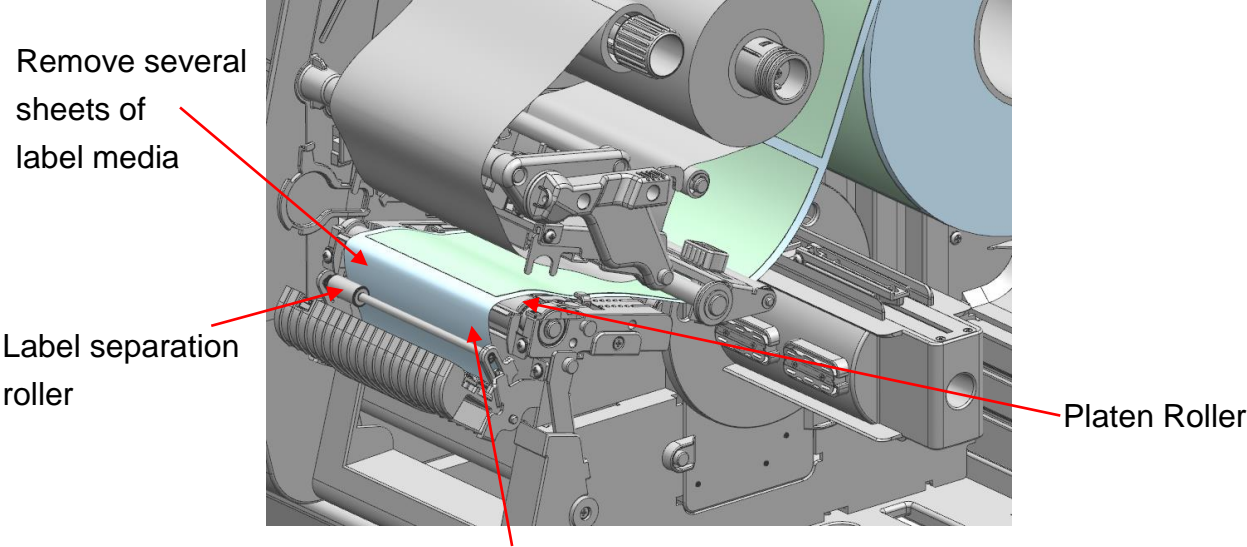

Insert media between platen roller and label separation roller

6) After installing the media in the same way as the picture, fix the media on rewriter media guide.

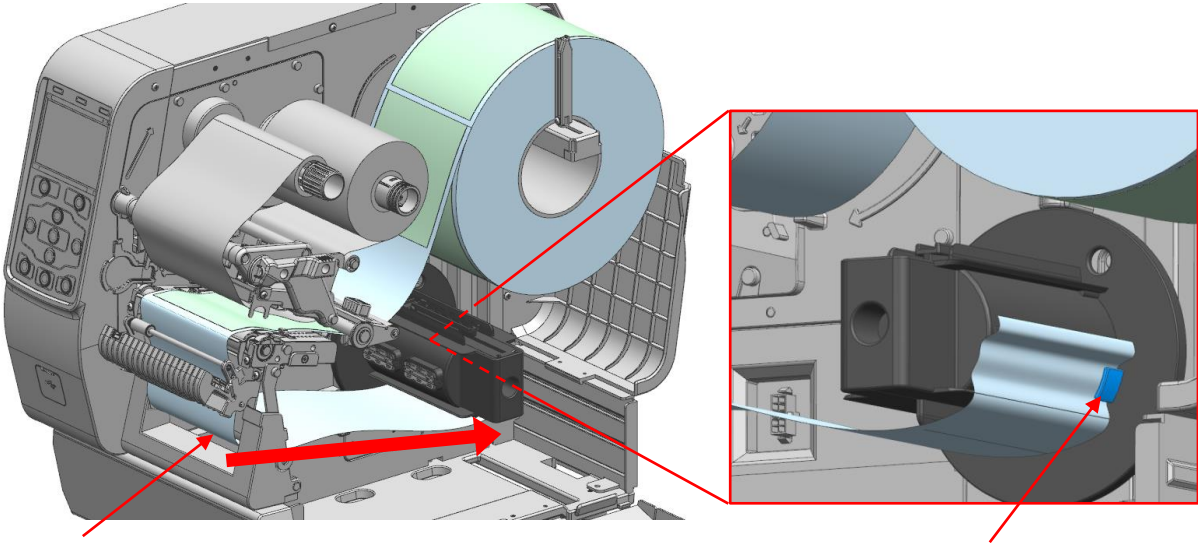

Insert media

Rewinder Media Guide

7) Adjust the rewriter fixing guides to the media width.

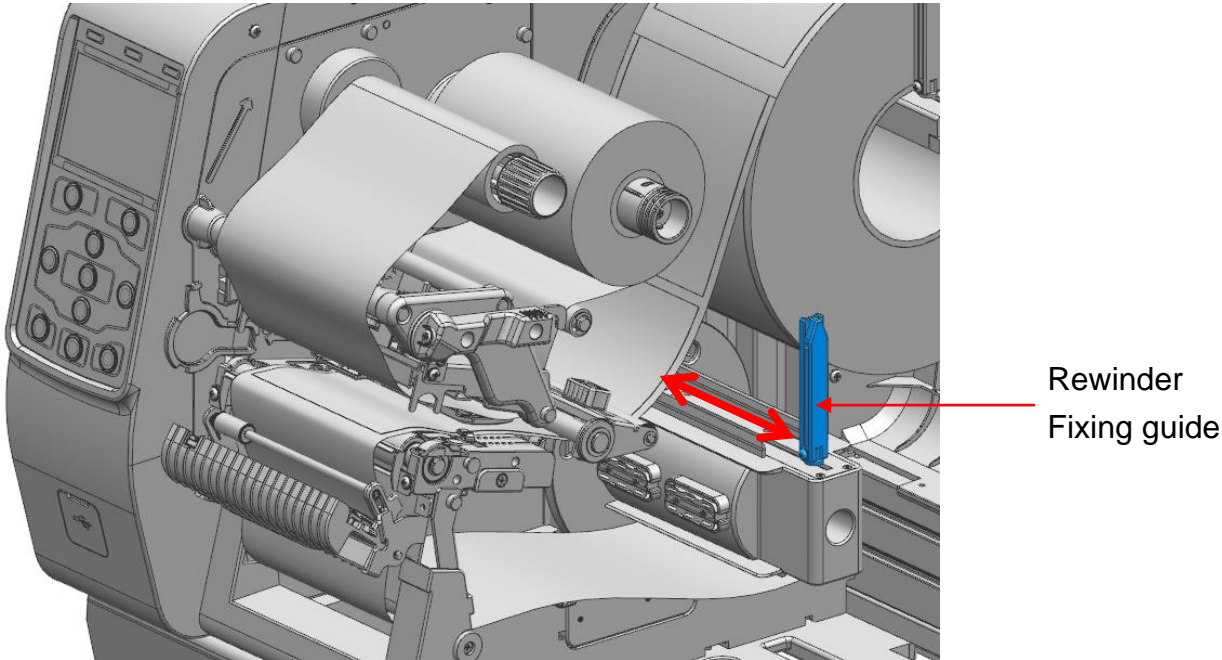

8) Close the peeler cover until it clicks.

(O)

(X)

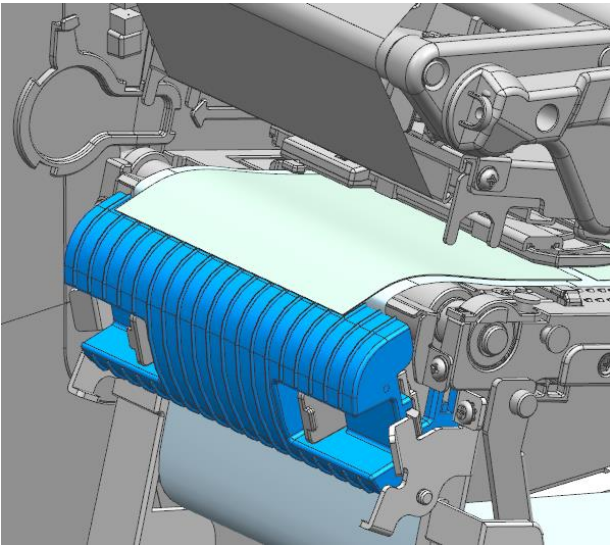
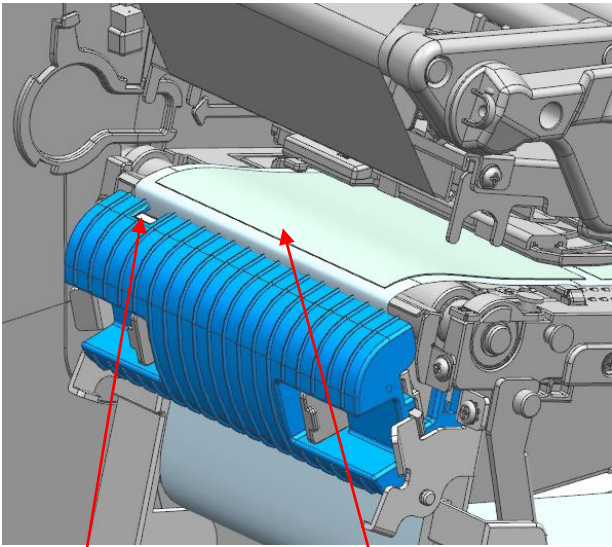



Peeler Sensor Be careful that the media does not cover the peeler sensor

9) Close the print head lever, the rewriter cover, and the media cover.

• Media Removal Method

- 1) Open the peeler cover, the media cover, the rewinder cover and the print head lever.
- 2) Please refer to Media Removal Method of 'Media Installation(Removal) Method - Not Using Media Core'.

 Note	- When removing the media, please work to avoid damaging the surrounding parts.
 Caution	<ul style="list-style-type: none">- When opening or closing the cover, be careful not to pinch your fingers.- Do not open the print head levers while the printer is printing. The printer may be damaged.- Change the media when the printer is not receiving data, or data may be lost.- The peeler function is only available for label media.- When the peeler is switched on, the next label will not be printed unless the printed label is removed from the peeler.- When the peeler is switched off, the peeler does not work.
 Warning	While the printer is operating, the print head gets very hot, so turn off the power and let it cool down completely. The hot print head can cause serious burns.

3-4-6 Media Installation method for 1inch Media Core (optional) Model

For 1inch Media Core Model, install media in the following ways:

- 1) Remove the current 3 inch media holder fixture from the printer using a hexagonal screwdriver (3mm).

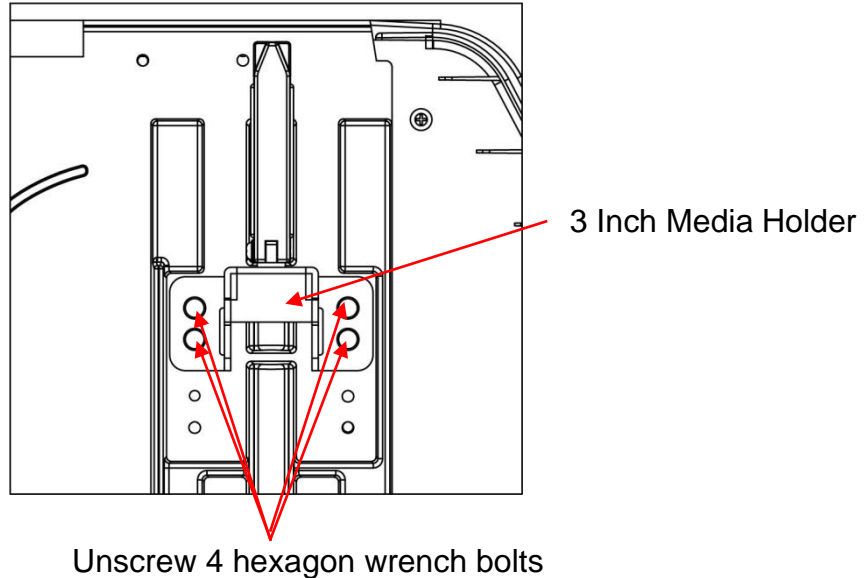

- 2) Assemble 1 inch media holder fixture(sold separately) with printer using a hexagonal driver (3mm).

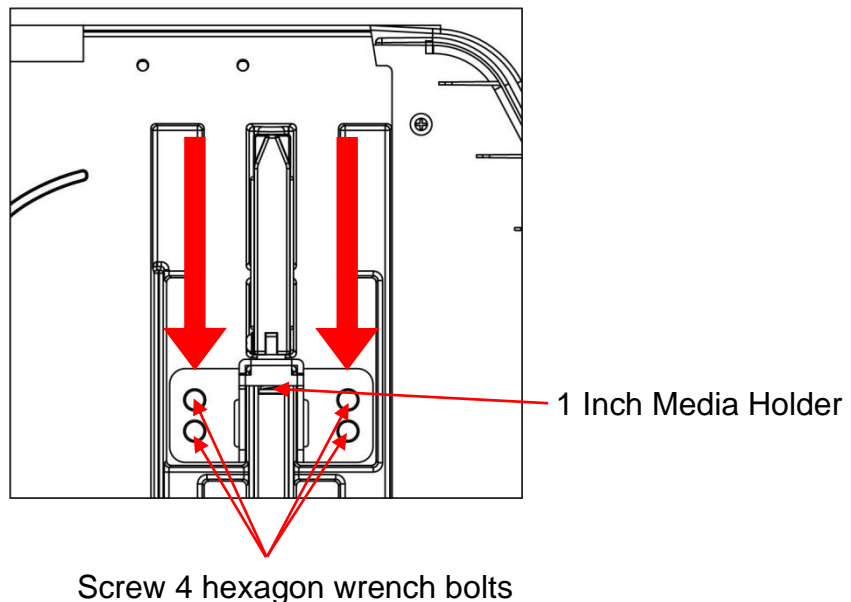

- 3) Install the media in the same manner as the 3 inch core paper model.



Note

1 inch media holder fixture can be purchased separately. Please contact the place of purchase.



Caution

Be sure to turn off the printer before replacing the media holder. The printer may be damaged.

3-4-7 How To Install Media Externally

Install media from outside the printer as follows.

1) Insert the media through the rear access slot of the printer.

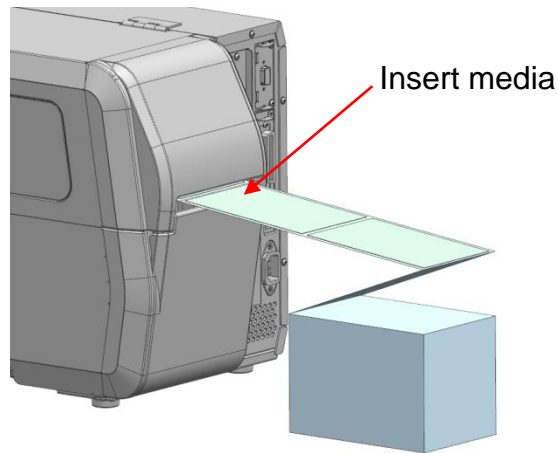

2) Adjust the media fixing guide to the media width.

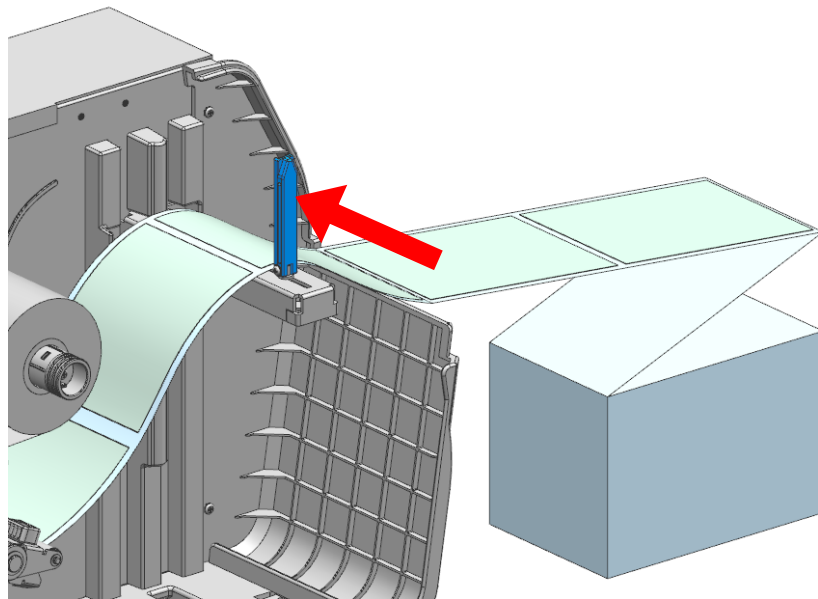

3) Close the print head lever and media cover.



Caution

- Do not open the print head levers while the printer is printing. The printer may be damaged.
- Change the media when the printer is not receiving data, or data may be lost.

3-5 How to Use Media Damper (Standard Model)

You can use the media damper to avoid the issue shown in the following images.



label stuck to the ribbon guide



folded label end when printing

1) Push the media damper button down to lift the media damper.

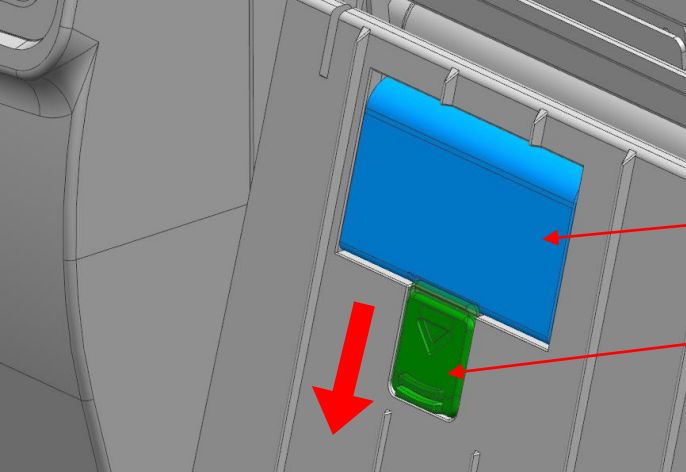

Media Damper

Media Damper Button

2) Use the printer with the media damper up as in the picture.
(Please refer to 3-4-1 Media Installation Method of Standard Model)

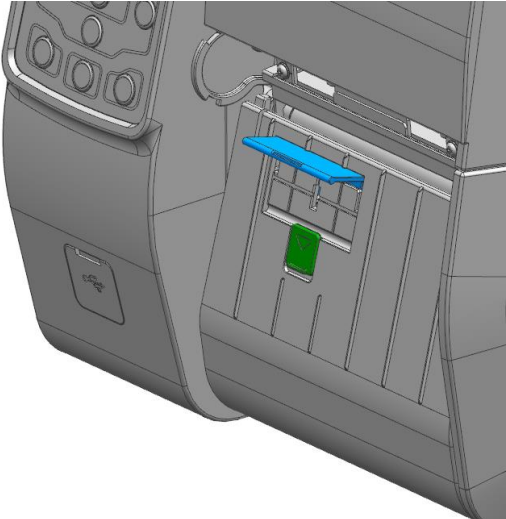

3-6 Ribbon Installation

3-6-1 Ribbon Type

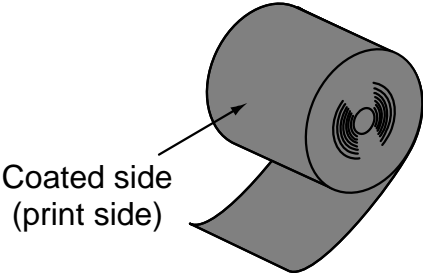

- 1) Type by film coating position
 - This printer can be used with both Outside and Inside Ribbon.

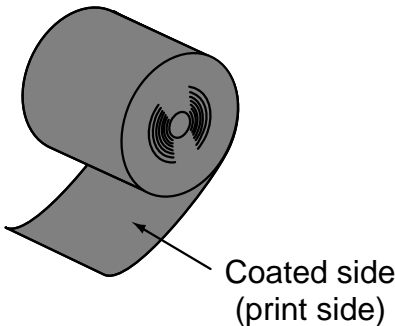

Outside Ribbon



Inside Ribbon

 Note	Perform an adhesion test to determine which side of the ribbon is coated. Follow these steps to check the coated side of the ribbon. 1) Remove the label from the liner. 2) Press one corner of the adhesive side of the label against the outside/inside of the surface of the ribbon. 3) Remove the label from the ribbon. 4) Check whether the black ink ribbon appears on the adhesive side of the label.
 Caution	Do not dispose of the ribbon core of spent ribbon because it will be reused.

- 2) Type by Ribbon core
 - This printer can be used only with the ribbon of 1 inch ribbon core.

3-6-2 Ribbon Installation Method

Install ribbon as follows.

1) Insert the ribbon core into the ribbon take-up spindle and insert the ribbon into the ribbon supply spindle.

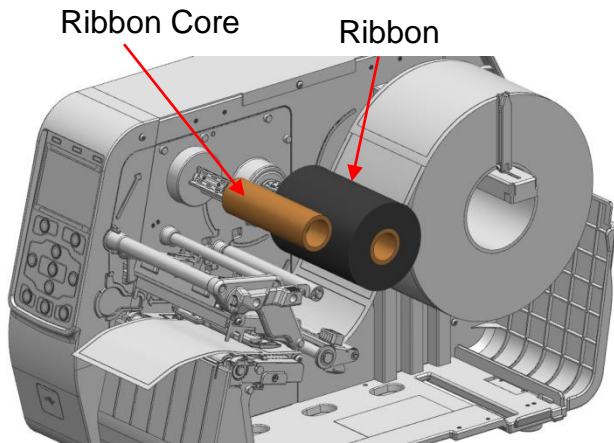

2) Open the print head lever and install the ribbon as shown below.

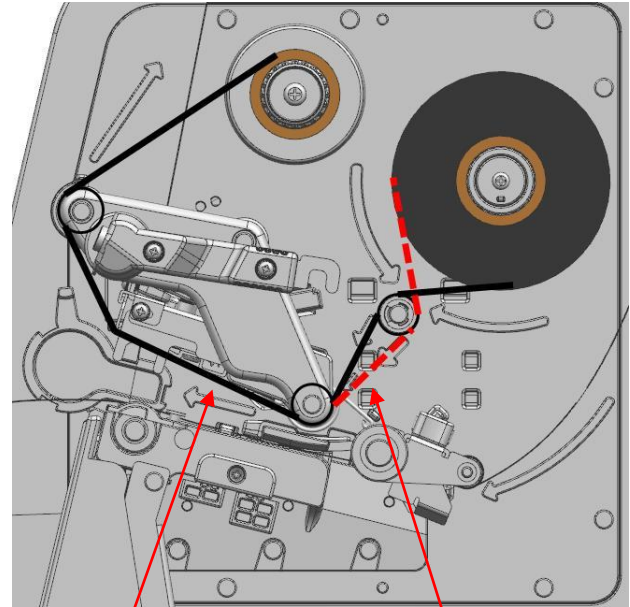

Outside Ribbon

Inside Ribbon

3) Attach the ribbon to the ribbon core using tape.

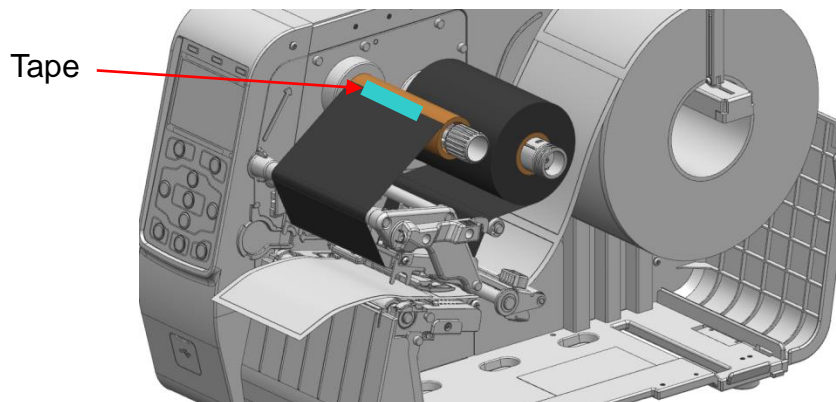

4) Close the print head lever and the media cover.



Caution

- When opening or closing the cover, be careful not to pinch your fingers.
- Do not open the print head levers while the printer is printing. The printer may be damaged.
- Change the media when the printer is not receiving data, or data may be lost.



Warning

While the printer is operating, the print head gets very hot, so turn off the power and let it cool down completely. The hot print head can cause serious burns.

3-6-3 Load Adjustment by Ribbon Length

The printer can use all 1 to 4 inch wide ribbons and is set to 4 inch wide ribbons when shipped from the factory. Adjust the ribbon supply spindle load according to the ribbon width.

- 1) When using ribbon of 3 inch or 4 inch width, pull in the direction of UP marked on the ribbon supply spindle until it clicks.

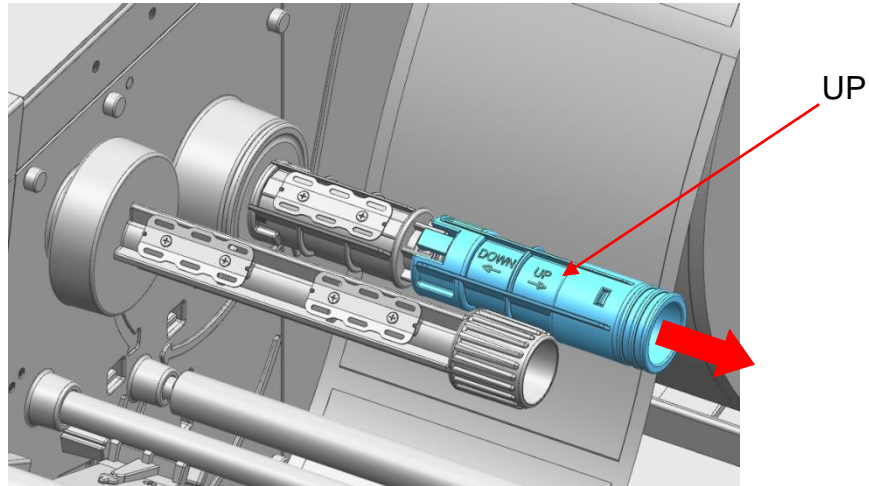

- 2) When using ribbon of 1 inch or 2 inch width, push in the direction of DOWN marked on the ribbon supply spindle until it clicks.

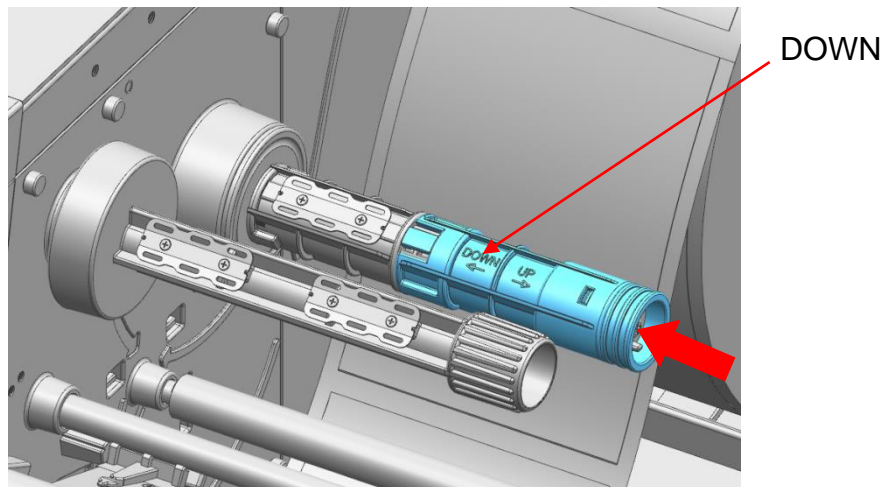

Caution

Do not adjust the ribbon supply spindle load while the printer is printing. The printer may be damaged.

3-6-4 Ribbon Remove Method

Remove the ribbons as follows.

1) Cut the ribbon.

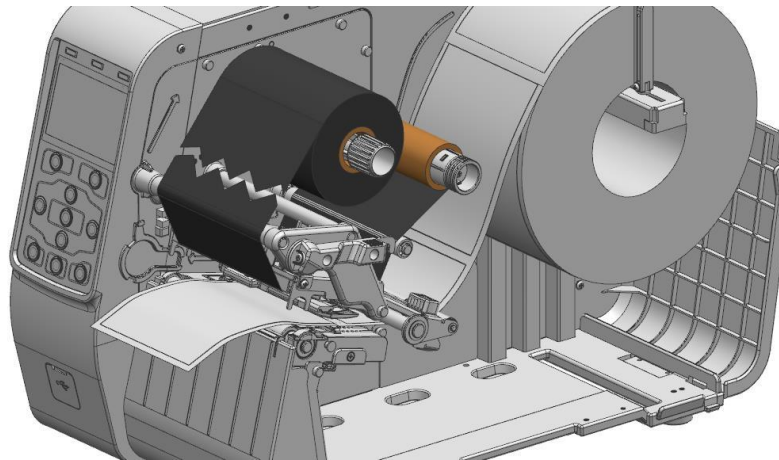

2) Open the print head levers and remove the ribbon and ribbon core from left to right.

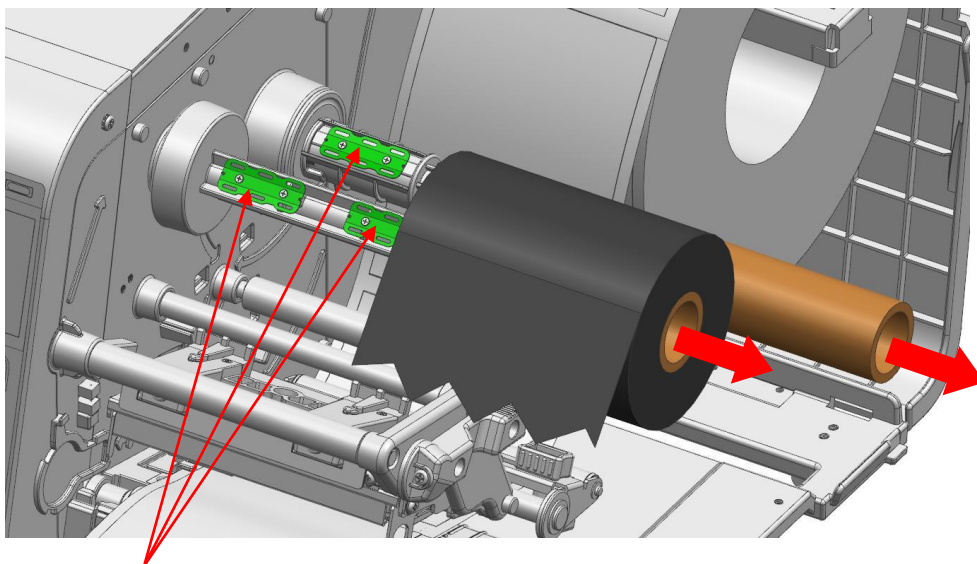

Ribbon Core Clip



Caution

Don't remove the ribbon and ribbon core while the printer is printing. The printer may be damaged.



Warning

When removing ribbon and ribbon core, be careful of the sharp end of the ribbon core clip. This can cause serious bodily injury.

3-7 Print Head Load Control Method

- Adjust the print head load by turning the left and right knobs depending on the media width and thickness. The left and right knobs are set to level 3 when shipped from the factory. Adjusting the print head load can improve the print quality.
 - ※ Turning the knob toward the level 1 (counterclockwise) direction reduces the print head load and the print density. Turning the knob toward level 5 (clockwise) increases the print head load and the print density.

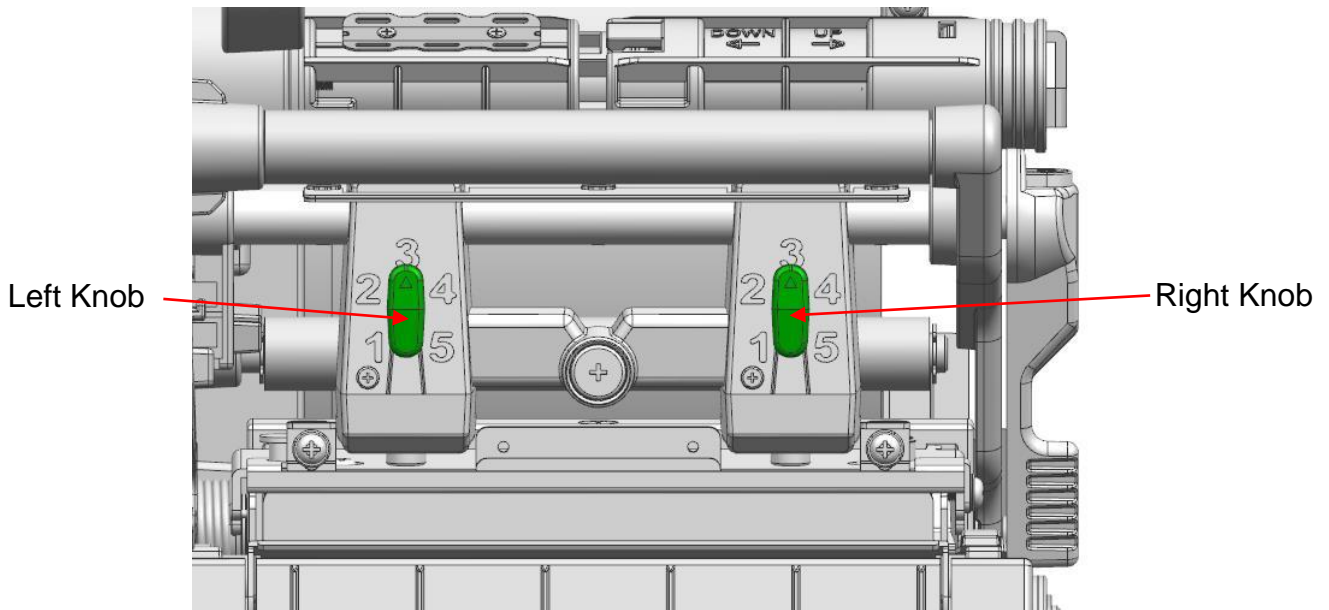

Caution

Do not adjust knobs while the printer is printing.
The printer may be damaged.

3-8 Ribbon Guide Control Method

• Wrinkles can be improved by adjusting A and B on the ribbon guides.

1) How to adjust ribbon guide A

- Slightly loosen the screw fastened to the ribbon guide A using a cross-tip screwdriver to adjust it up and down.

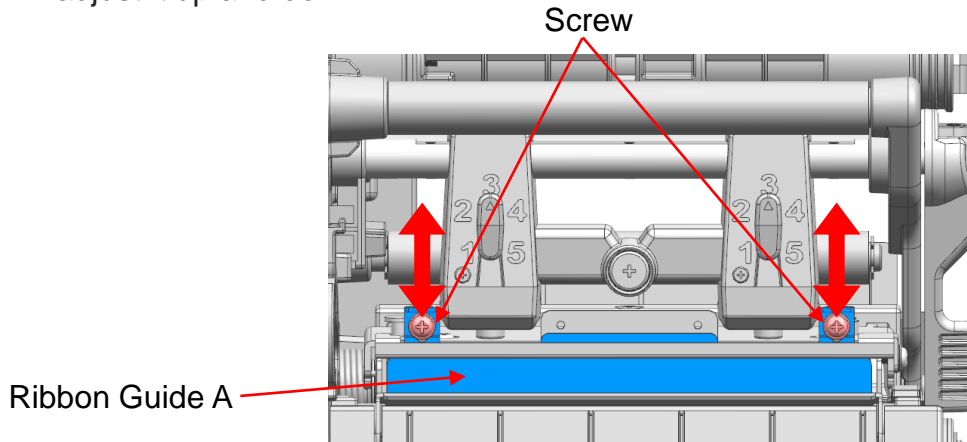

2) How to adjust ribbon guide B

- Slightly loosen the screw fastened to the ribbon guide B using a cross-tip screwdriver to adjust it forward and backward.

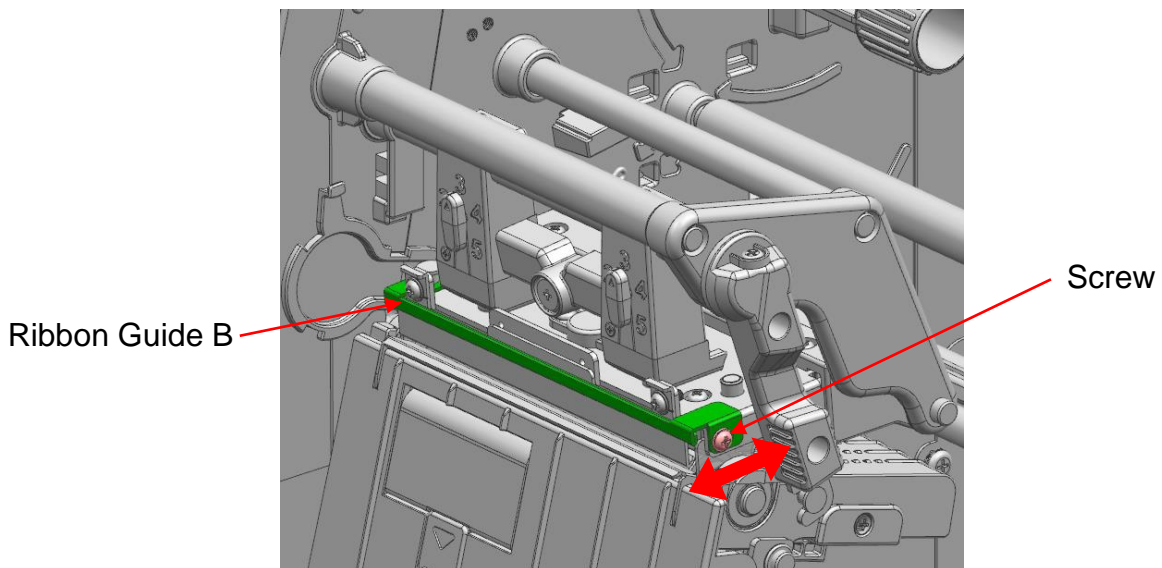

Do not adjust ribbon guide while the printer is printing.
The printer may be damaged.

3-9 How to Fine Tune Print Head Position

- When using special paper, you can fine tune the print head position. There is no need to do this when using standard paper.

By fine tuning the print head position, you can improve the printing quality.

- 1) Turn off the printer.
- 2) Unplug the power cord from the printer.
- 3) Open the print head lever. Push the shaft down to remove the print head bundle which is attached by magnetism.

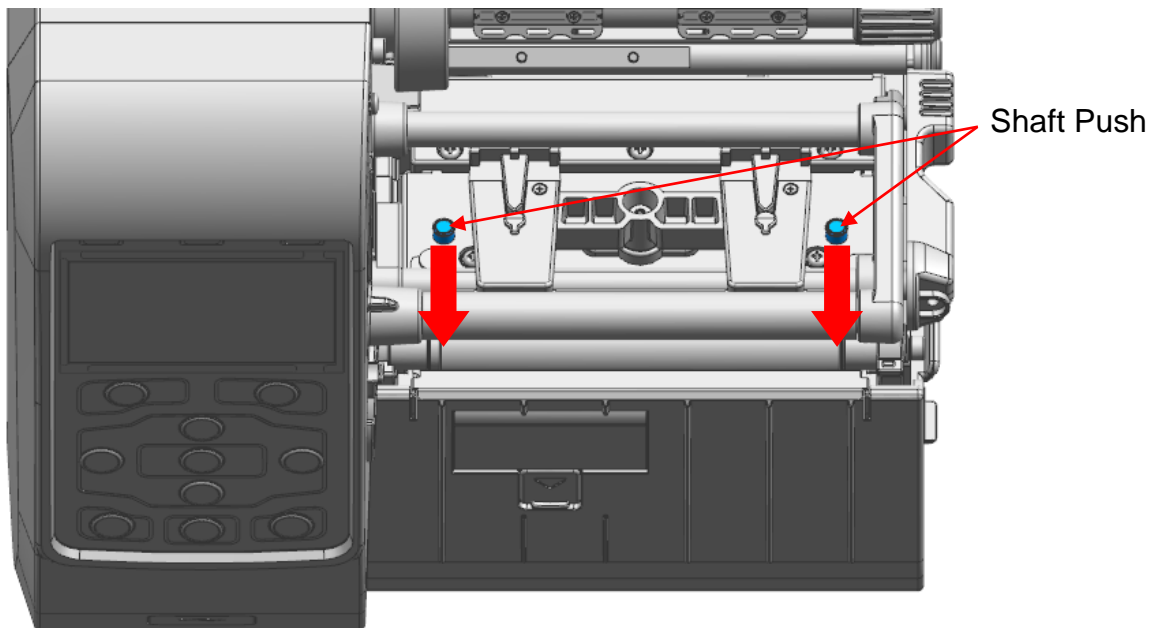

- 4) Remove the connector connected to the print head bundle.

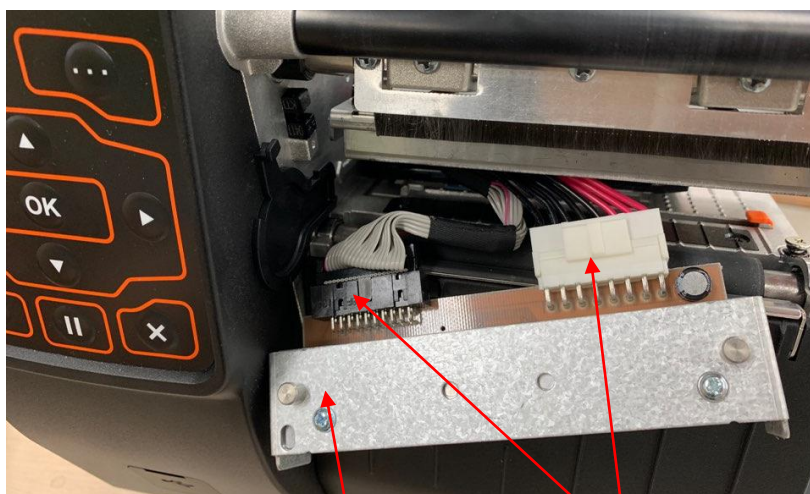

Print Head Ass'y

Connector

5) After loosening the screws using a cross-tip screwdriver, adjust the print head position.

※ Move the print head in direction ① if you are using thick paper (0.26~0.3mm).

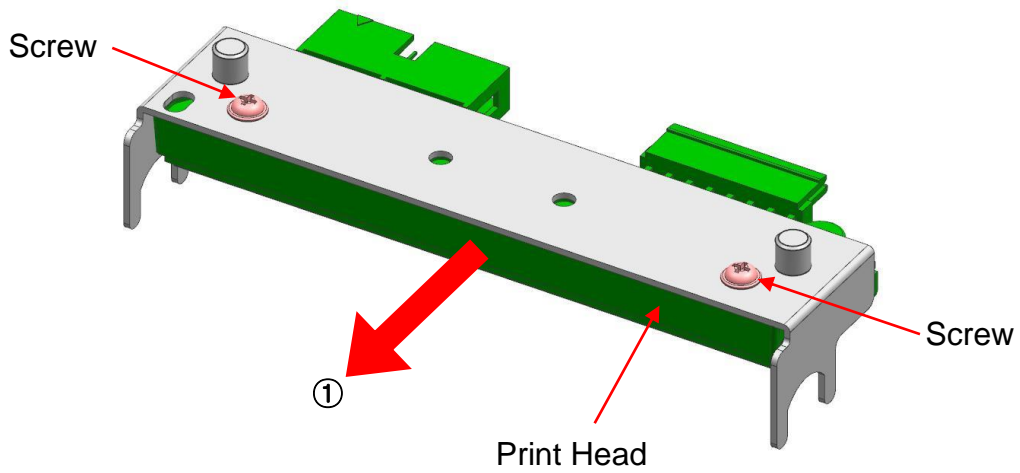

※ The factory default position of the print head (green side) is 0.6mm from the red guide in direction ②.

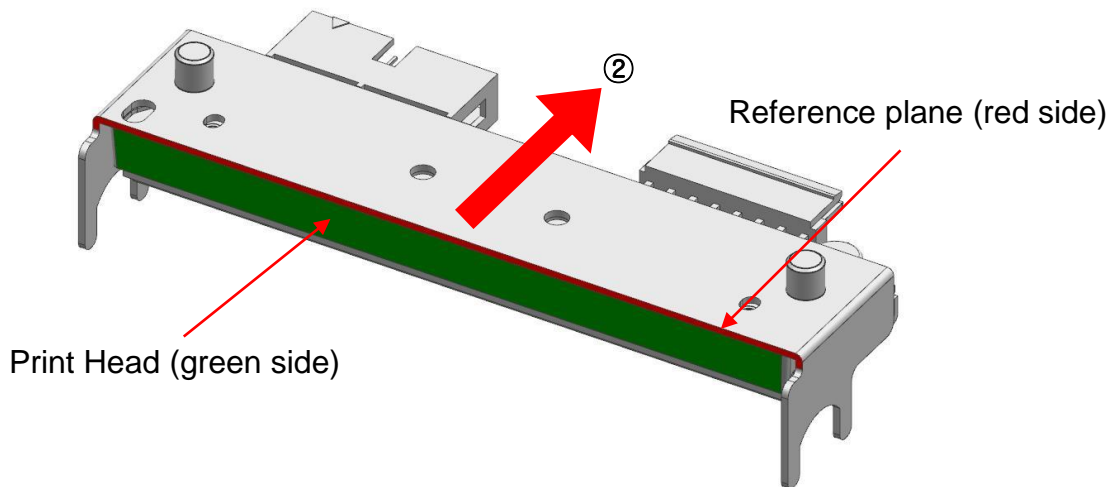

6) After fine tuning the position, re-assemble in reverse order of disassembly.

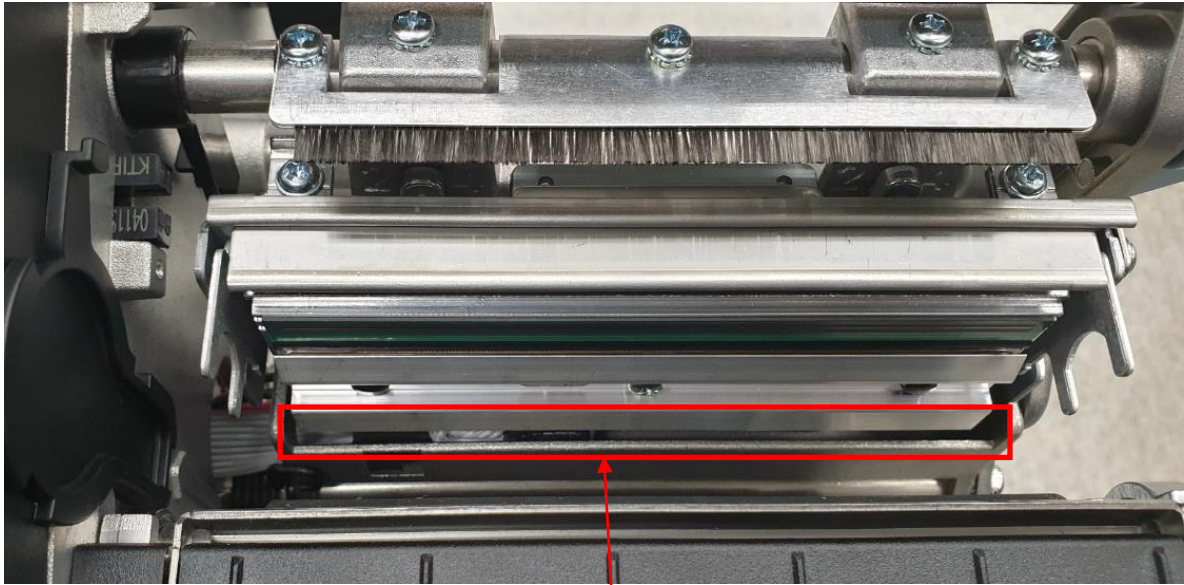

Be careful not to let the wires come out.

 **Caution**

- Do not adjust the print head position while the printer is in operation as it may cause damage.
- Fine tuning the print head position significantly affects the printing quality. Perform this process only when necessary.

4. Printer Setting

4-1 Menu Composition(Standard Model)

	Explanation		
			Print Width
			Print Length
			Print Direction
			Print Speed
			Print Density
			Print Method
			Media Type
			Tear Off
			Print Offset
			Left Position
			Print Mode
			Power Up Action
			Print Head Close

	Explanation		
	Serial		Baud Rate
			Data Bits
			Parity
			Stop Bit
			Host Handshake
	Ethernet		IP Protocol
			IP Address
			Subnet Mask
			Gateway
			MAC Address
	WLAN		Channel
			Network
			ESSID (APID)
			Auth (Authentication)
			Encrypt (Encryption)
			WEP Password
			PSK Password
			IP Protocol
			IP Address
		Subnet Mask	
	Gateway		
	Smart Connection active		

	Bluetooth	Device Name	
		Pairing	Pincode
			SSP(Secure Simple Pairing)
		MAC Address	
		Mode	Bluetooth Low Energy
Standard Mode	Connect Mode Auth&Enc (Authentication & Encryption)		
Interface Info			

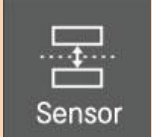
	Explanation	
	Gap Calibration	
	Black Mark Calibration	
	Sensor Sensitivity	

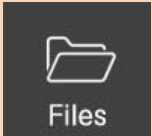
	Explanation	
	Saved File	Template
		Image
		Download Font
		E Drive (Flash Memory)
		A Drive (USB Memory)
		B Drive (SD Card Memory)
	Twin Function	Printer Setting
		Template
		Image
Download Font		
Firmware Update		

	Explanation	
	Self Test	
	Factory Reset	
	Dump Mode	
	Print Head Check	
	LCD	Dead Pixel Test
		Backlight Brightness
	Real Time Clock	Date Setting
		Time Setting
		Date Format
		Time Format
	Language Setting	
	Emulation	
	USB Serial Number	
	Buzzer Setting	
	Security	Password Enable
		Password Setting
Demo Print		

Explanation	
 Printer Info	Media Installation
	Media Installation (Peel Off)
	Media Installation (Rewinder)
	Ribbon Installation
	Peel off Installation
	Auto Cutter Installation
	Replace Media
	Replace Ribbon
	Replace Print Head
	Installation & Usage
Troubleshooting	
Contact US	

4-2 Menu Composition(Touch Screen Model)

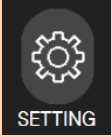
	Explanation		
		Print Width	
		Print Length	
		Print Direction	
		Print Speed	
		Print Density	
		Print Method	
		Media Type	
		Tear Off	
		Print Offset	
		Left Position	
		Print Mode	
		Power Up Action	
		Print Head Close	

	Explanation		
	Serial	Baud Rate	
		Data Bits	
		Parity	
		Stop Bit	
		Host Handshake	
	Ethernet	IP Protocol	
		IP Address	
		Subnet Mask	
		Gateway	
		MAC Address	
	WLAN	Channel	
		Network	
		ESSID (APID)	
		Auth (Authentication)	
		Encrypt (Encryption)	
		WEP Password	
		PSK Password	
		IP Protocol	
		IP Address	
Subnet Mask			
Gateway			
Smart Connection active			

XT5-40 Series

	Bluetooth	Device Name	
		Pairing	Pincode
			SSP(Secure Simple Pairing)
		MAC Address	
		Mode	Bluetooth Low Energy
	Standard Mode		Connect Mode Auth&Enc (Authentication & Encryption)
Interface Info			

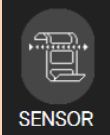
	Explanation	
	Gap Calibration	
	Black Mark Calibration	
	Sensor Sensitivity	

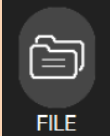
	Explanation	
	Saved File	Template
		Image
		Download Font
		E Drive (Flash Memory)
		A Drive (USB Memory)
		B Drive (SD Card Memory)
	Twin Function	Printer Setting
		Template
		Image
		Download Font
	Firmware Update	

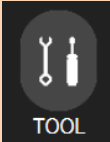
		Explanation
	Self Test	
	Factory Reset	
	Dump Mode	
	Print Head Check	
	LCD	Dead Pixel Test
		Touch Position Test
		Backlight Brightness
	Real Time Clock	Date Setting
		Time Setting
		Date Format
		Time Format
	Language Setting	
	Emulation	
	USB Serial Number	
	Buzzer Setting	
	Security	Password Enable
Password Setting		
Demo Print		

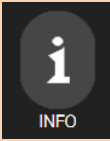
		Explanation
	Printer Info	
	Installation & Usage	Media Installation
		Media Installation (Peel Off)
		Media Installation (Rewinder)
		Ribbon Installation
		Peel off Installation
		Auto Cutter Installation
		Replace Media
		Replace Ribbon
		Replace Print Head
	Troubleshooting	
	Contact US	

4-3 Menu Select Method(Standard Model)

1) This is print ready status LCD output screen.

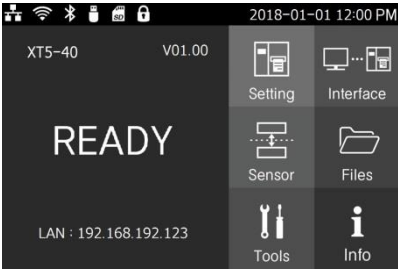

2) Press function button, direction button or OK button.



3) The setting menu is selected.

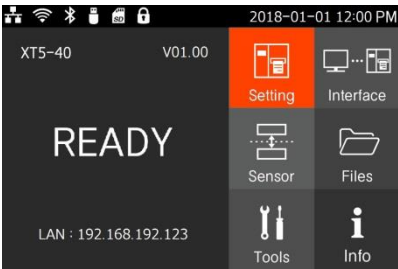

4) Use direction buttons to move to the desired menu.

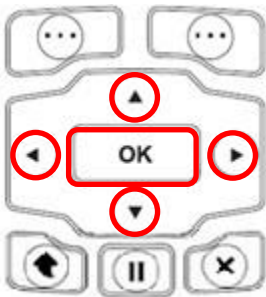

5) Press OK or the right function button to enter the sub menu.

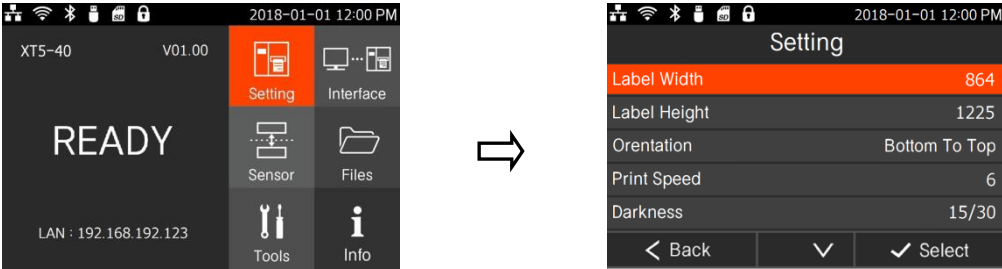



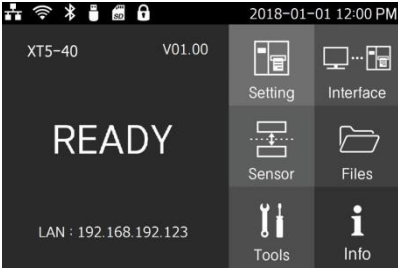

6) If there are no input for 5 seconds, it returns to main screen









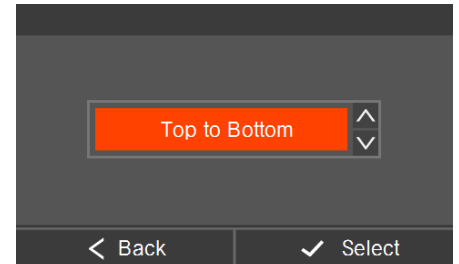



4-4 Setting Confirm Method(Standard Model)

1) How to use the up and down buttons

- (1) Select the desired setting value using  or  button
- (2) After selecting the setting value, save it with  button
- (3) If you want to exit the menu without setting, press  button to move to the previous screen



2) How to input numbers

- (1) Select the desired input value using , , ,  button
- (2) Enter the desired value using  button
- (3) With , you can delete the input value
- (4) With  , you can move the cursor
- (5) After entering set value, save it using  button
- (6) If you want to exit the menu without setting, press  button to move to the previous screen

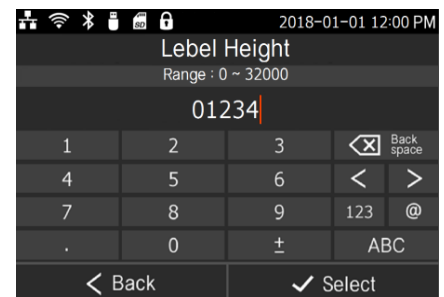

3) How to input characters

- (1) Select the desired input value using ▲, ▼, ◀, ▶ button
- (2) Enter the desired value using button
- (3) With , you can delete the input value
- (4) With , you can move the cursor
- (5) With , you can move to the numeric input screen
- (6) With , you can move to the symbol input screen
- (7) With , you can move to lower case input screen
- (8) After entering set value, save it using button
- (9) If you want to exit the menu without setting, press button to move to the previous screen

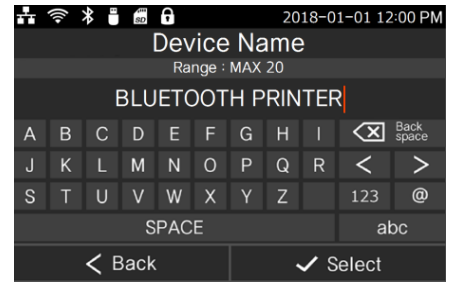

4-5 Menu Select Method (Touch Screen Model)

1) This is print ready status

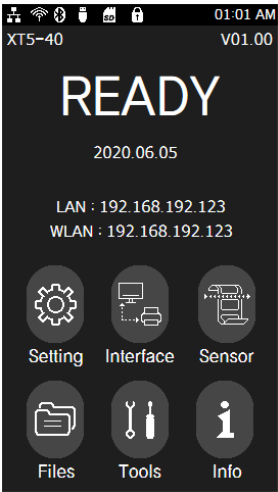

2) Press the setting menu.

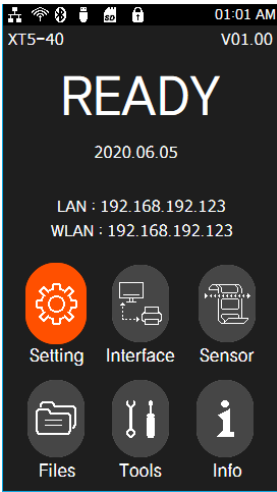

3) Press screen to enter the sub menu.

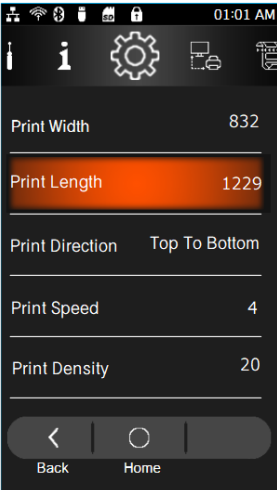
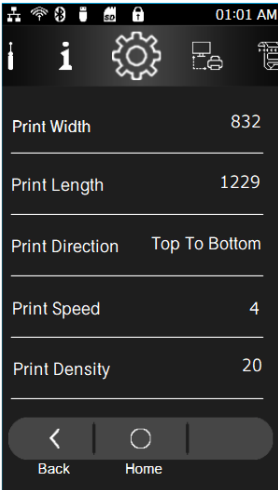



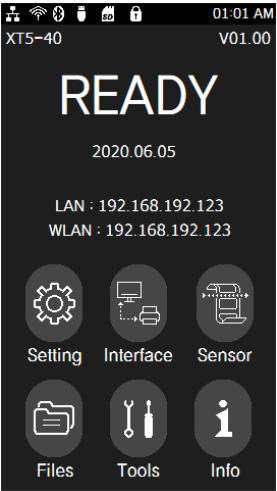



4) If there are no input for 5 seconds, it returns to main screen .

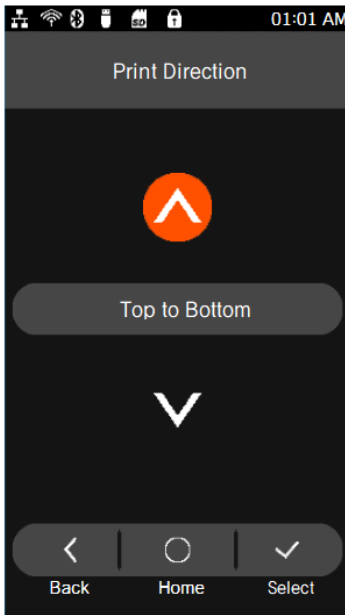

4-6 Setting Confirm Method(Touch Screen Model)





1) How to use the up and down buttons

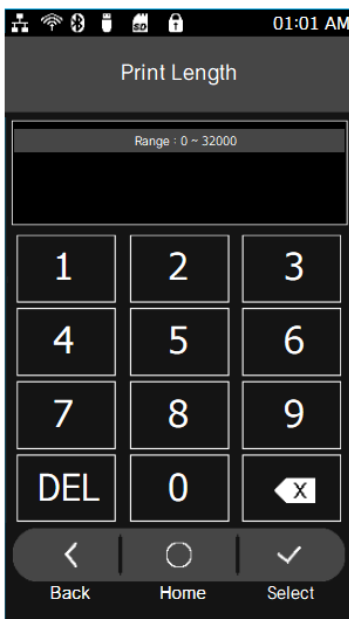

- (1) Select the desired setting value using  or  button
- (2) After selecting the setting value, save it with  button
- (3) If you want to exit the menu without setting, press  button to move to the previous screen
- (4) If you want to exit the menu without setting, press  button to move to the main screen





2) How to input numbers

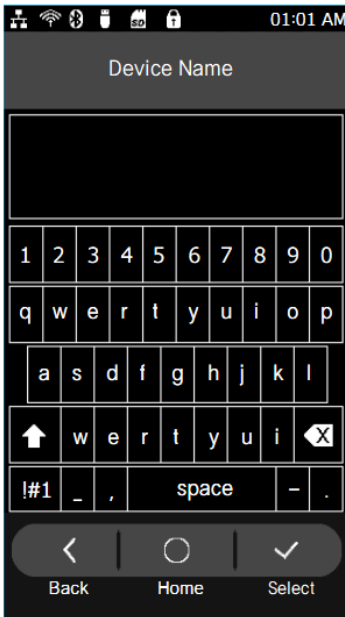

- (1) Select the desired setting value using number keypad.
- (2) With , you can delete the input value.
- (3) With , you can delete the all input value.
- (4) After selecting the setting value, save it with  button
- (5) If you want to exit the menu without setting, press  button to move to the previous screen
- (6) If you want to exit the menu without setting, press  button to move to the main screen





3) How to input characters(English only)

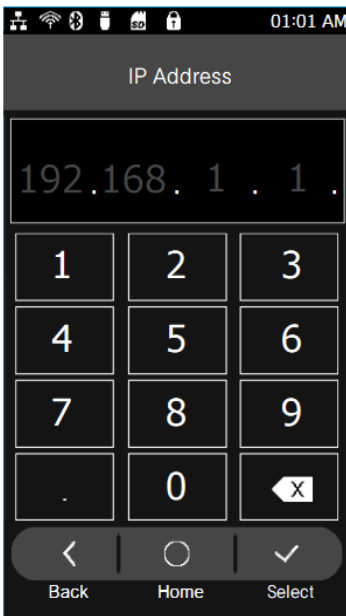

- (1) Select the desired setting value using keypad.
- (2) With , you can delete the input value.
- (3) With , you can input the capital letter.
- (4) After selecting the setting value, save it with  button
- (5) If you want to exit the menu without setting, press  button to move to the previous screen
- (6) If you want to exit the menu without setting, press  button to move to the main screen

4) How to input IP address



- (1) Select the desired IP Address using number keypad.
- (2) With , you can delete the input value.
- (3) With , you can input the Dot(.)
 - * from 0 to 99, press Dot(.) to move next
 - * from 100 to 255, Dot(.) would be automatically generated.
- (4) After selecting the setting value, save it with  button
- (5) If you want to exit the menu without setting, press  button to move to the previous screen
- (6) If you want to exit the menu without setting, press  button to move to the main screen

4-7 Setting Menu Explanation(Standard, Touch Screen Model)

List	Explanation
Print Width	<p>Explanation Setting media width[dots] Function to adjust image buffer size according to print width</p> <p>Default Value 203dpi: 832dots 300dpi: 1248dots 600dpi: 2496dots</p> <p>Maximum Value 203dpi: 832dots 300dpi: 1248dots 600dpi: 2496dots</p>
Print Length	<p>Explanation Setting media length[dots] Function to adjust image buffer size according to print length</p> <p>Default Value 203dpi: 1225dot (153mm) 300dpi: 1811dot (150mm) 600dpi: 3622dot (150mm)</p> <p>Maximum Value 203dpi: 32000dot (4000mm) 300dpi: 30000dot (2500mm) 600dpi: 24000dot (1000mm)</p>

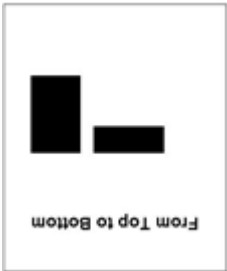
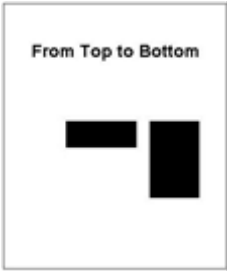
<p>Print Direction</p>	<p>Explanation Setting printing direction Top to bottom: Printing from top to bottom Bottom to Top: Printing from bottom to top</p> <p>Default Value Bottom to Top</p> <p>Variable Value Bottom to Top, Top to Bottom</p> <p style="text-align: center;">Printing Direction</p> <div style="display: flex; justify-content: space-around; align-items: center;"><div style="text-align: center;"><p>Top to bottom</p></div><div style="font-size: 2em; margin: 0 20px;">↓</div><div style="text-align: center;"><p>Bottom to top</p></div></div>
<p>Print Speed</p>	<p>Explanation Setting print speed[ips]</p> <p>Default Value 203dpi: 6ips 300dpi: 6ips 600dpi: 3ips</p> <p>Variable Value 203dpi: 2 ~ 14ips 300dpi: 2 ~ 10ips 600dpi: 1 ~ 5ips</p>
<p>Print Density</p>	<p>Explanation Setting print density</p> <p>Default Value 203dpi: 15 300dpi: 15 600dpi: 15</p> <p>Variable Value 0 ~ 30</p>

Print Method	Explanation Setting print method Default Value Transfer Variable Value Transfer, Direct
Media Type	Explanation Setting media type Default Value Gap Variable Value Gap, Black Mark, Continuous
Tear Off	Explanation Setting media position[dots] for tear off after printing or feed Default Value 0 Variable Value -100 ~ 100
Print Offset	Explanation Setting top print position[dots] Default Value 0 Variable Value -100 ~ 100
Left Position	Explanation Setting left print position[2dots] Default Value 0 Variable Value -300 ~ 300
Print Mode	Explanation Setting print mode suitable to the printer option Default Value Tear Off Variable Value Tear Off, Auto Cutter, Rewinder

Power Up Action	Explanation Setting the action for the printer after the power-up sequence. Default Value No Feed Variable Value No Feed, Set Label Length, Media Calibration, Feed
Print Head Close	Explanation Setting the action for the printer when you close the print head Default Value Feed Variable Value Feed, Standby Mode, No Feed, Set Label Length, Media Calibration

4-8 Interface Menu Explanation(Standard, Touch Screen Model)**4-8-1 Serial**

List	Explanation
Baud Rate	<p>Explanation Setting the baud rate</p> <p>Default Value 115200</p> <p>Variable Value 9600,19200,38400,57600,115200</p>
Data Bits	<p>Explanation Setting the data bit</p> <p>Default Value 8</p> <p>Variable Value 7, 8</p>
Parity	<p>Explanation Setting the parity</p> <p>Default Value None</p> <p>Variable Value None, Odd, Even</p>
Stop Bit	<p>Explanation Setting the stop bit</p> <p>Default Value 1</p> <p>Variable Value 1, 2</p>
Host Handshake	<p>Explanation Setting the handshake</p> <p>Default Value RTS_CTS</p> <p>Variable Value RTS_CTS, DTR_DSR, XON_XOFF</p>

4-8-2 Ethernet

List	Explanation
IP Protocol	Explanation Setting IP assignment method Default Value DHCP Variable Value DHCP, Static IP
IP Address	Explanation Setting IP Address method Default Value Static IP: 192.168.192.123 DHCP: 0.0.0.0 Variable Value 0 ~ 255
Subnet Mask	Explanation Setting subnet mask Default Value Static IP: 255.255.255.0 DHCP: 0.0.0.0 Variable Value 0 ~ 255
Gateway	Explanation Setting gateway Default Value Static IP: 192.168.192.254 DHCP: 0.0.0.0 Variable Value 0 ~ 255
MAC Address	Explanation Indicating MAC address

4-8-3 WLAN

List	Explanation
Channel	<p>Explanation Setting channel when creating Adhoc network</p> <p>Default Value 6</p> <p>Variable Value 1 ~ 14</p>
Network	<p>Explanation Setting WLAN operation mode</p> <p>Default Value Soft AP</p> <p>Variable Value Soft AP, Infrastructure, Adhoc, P2P</p>
ESSID	<p>Explanation Setting the ID of AP to be accessed</p> <p>Default Value PRINTER_xxxxxx(product specific value)</p>
Auth	<p>Explanation Setting WLAN authentication method</p> <p>Default Value Open System</p> <p>Variable Value Open System, Shared Key, WPA1PSK, WPA2PSK, WPA1EAP, WPA2EAP</p>
Encrypt	<p>Explanation Setting WLAN encryption method</p> <p>Default Value None</p> <p>Variable Value None, WEP64/128, TKIP, AES, AES+TKIP</p>
WEP Password	<p>Explanation Setting WEP password</p>
PSK Password	<p>Explanation Setting PSK password</p>

IP Protocol	Explanation Setting IP assignment method Default Value DHCP Variable Value Static IP, DHCP
IP Address	Explanation Setting IP address Default Value Static IP: 192.168.1.1 DHCP: 0.0.0.0 Variable Value 0 ~ 255
Subnet Mask	Explanation Setting subnet mask Default Value Static IP: 255.255.255.0 DHCP: 0.0.0.0 Variable Value 0 ~ 255
Gateway	Explanation Setting gateway Default Value Static IP: 192.168.1.254 DHCP: 0.0.0.0 Variable Value 0 ~ 255
Smart Connection active	Explanation After searching a Smart Connection Act Enabled printer with the smart phone app, enable or disable the function synchronizing Wi-Fi login information connected to the smart phone. Default Value Disable Variable Value Disable, Enable

4-8-4 Bluetooth

List		Explanation	
Device Name		Explanation Name of Device	
Pairing	Pincode	Explanation Changes required pin code to connect	
	SSP	Explanation Secures simple pairing Default Value Disable Variable Value Disable, Just Works, Numeric Comparison, Passkey Entry	
MAC Address		Explanation Bluetooth device MAC address	
Mode	Bluetooth Low Energy	Explanation Bluetooth Low Energy Default Value Disable Variable Value Disable, Enable	
	Standard Mode	Connect Mode	Explanation Setting Bluetooth connection mode Default Value Mode 2 Variable Value Mode 1, Mode 2, Mode 3
		Auth&Enc	Explanation Setting Bluetooth authentication and encryption function Default Value Enable Variable Value Enable, Disable

4-9 Sensor Menu Explanation(Standard, Touch Screen Model)

List	Explanation
Gap Calibration	Explanation Detect media gap and calibrate automatically
Black Mark Calibration	Explanation Detect media black mark and calibrate automatically
Sensor Sensitivity	Explanation Adjusts the sensitivity of the gap sensor Default Value 70 Variable Value 10 ~ 100

**Note**

- Depending on the characteristics of the media, the amount of media output may be different during gap / black mark calibration.

4-10 Files Menu Explanation

List	Explanation		
Files	Saved File	Template	Refer 4-10-1 Saved File
		Image	
		Download Fonts	
		E Drive (Flash Memory)	
		A Drive (USB Memory)	
	Twin Function	B Drive (SD Card Memory)	Refer 4-10-2 Twin Function
		PRT Set (Printer Setting)	
		Template	
		Image	
	F/W Update	Download Fonts	Refer 4-10-3 F/W Update

4-10-1 Saved File

Displays the list of object files stored in the printer on the LCD screen.

List	Explanation
Template	Template list stored in the printer
Image	Image list stored in the printer (*.pcx)
Download Font	Download font list stored in the printer
E Drive (Flash Memory)	Saved object files in E drive
A Drive (USB Memory)	Saved object files in A drive
B Drive (SD Card Memory)	Saved object files in B drive

4-10-2 Twin Function

Saves the current printer settings, save files (templates, images, download fonts) to another printer using USB, or loads the settings of another printer and saves files to the current printer.

List	Explanation
Printer Setting	Explanation Saves printer settings to a USB storage device, or loads the print settings from USB storage. File path F:\configuration
Template	Explanation Saves template file to a USB storage device, or load the template from USB storage. File path F:\USER_AREA_TEMPLATES
Image	Explanation Saves image file to a USB storage device, or load the image from USB storage (*.pcx) File path F:\USER_AREA_Images
Download Font	Explanation Saves download font file to a USB storage device, or load the download font from USB storage. File path F:\USER_AREA_FONTS

List	Explanation
Printer Setting	<p>Explanation Saves printer settings to a USB storage device, or loads the print settings from USB storage.</p> <p>File path F:\configuration</p> <ul style="list-style-type: none">• Save Function Explanation<ul style="list-style-type: none">- Connect a USB storage to the printer.- Select Save on the menu using the up and down buttons.- The printer_config file is created in the configuration folder of USB storage device. (The configuration folder is automatically created)• Load Function Explanation<ul style="list-style-type: none">- Check whether the printer_config file exists in the configuration folder of the USB storage device. (If there is no file, save the printer settings first.)- Connect the USB storage to the printer.- Select Load from the Printer Setup menu using the up and down buttons.- Loading message is displayed while loading, and when loading is completed, USB loading completion message is displayed.- Check the change of the printer's settings.

List	Explanation
Template	<p>Explanation Saves template file to a USB storage device, or load the template from USB storage.</p> <p>File path F:\USER_AREA_TEMPLATES</p> <ul style="list-style-type: none">• Save Function Explanation<ul style="list-style-type: none">- Connect a USB storage to the printer.- Select Save on the menu using the up and down buttons.- Template files are stored in the USER_AREA_TEMPLATES folder of USB storage device. (USER_AREA_TEMPLATES folder is automatically created)• Load Function Explanation<ul style="list-style-type: none">- Check whether a template file exists in the USER_AREA_TEMPLATES folder of the USB storage device. (If the file does not exist, create a USER_AREA_TEMPLATES folder and save the template file to be copied to the printer below first)- Connect the USB storage to the printer.- Select Load from the Printer Setup menu using the up and down buttons.- Loading message is displayed while loading, and when loading is completed, USB loading completion message is displayed.- Go to Save File menu then, check the template file is normally saved to the printer.

List	Explanation
Image	<p>Explanation Saves image file to a USB storage device, or load the image from USB storage (*.pcx)</p> <p>File path F:\ USER_AREA_Images</p> <ul style="list-style-type: none">• Save Function Explanation<ul style="list-style-type: none">- Connect a USB storage to the printer.- Select Save on the menu using the up and down buttons.- Image files are stored in the USER_AREA_Images folder of USB storage device. (USER_AREA_Images folder is automatically created)• Load Function Explanation<ul style="list-style-type: none">- Check whether the image file exists in the USER_AREA_Images folder of the USB storage device. (If there is no file, create the USER_AREA_Images folder and save the image file to be copied to the printer below first.)- Connect the USB storage to the printer.- Select Load from the Printer Setup menu using the up and down buttons.- Loading message is displayed while loading, and when loading is completed, USB loading completion message is displayed.- Go to Save File menu then, check the image file is normally saved to the printer.

List	Explanation
Download Font	<p>Explanation Saves download font file to a USB storage device, or load the download font from USB storage.</p> <p>File path F:\USER_AREA_FONTS</p> <ul style="list-style-type: none">• Save Function Explanation<ul style="list-style-type: none">- Connect a USB storage to the printer.- Select Save on the menu using the up and down buttons.- Download Font files are stored in the USER_AREA_FONTS folder of USB storage device. (USER_AREA_FONTS folder is automatically created)• Load Function Explanation<ul style="list-style-type: none">- Check if the downloaded font file exists in the USER_AREA_FONTS folder of the USB storage device. (If there is no file, create the USER_AREA_FONTS folder and save the download font file to be copied to the printer below first.)- Connect the USB storage to the printer.- Select Load from the Printer Setup menu using the up and down buttons.- Loading message is displayed while loading, and when loading is completed, USB loading completion message is displayed.- Go to Save File menu then, check the download font file is normally saved to the printer.

4-10-3 Firmware Update

Firmware can be updated through USB storage.

<p>F/W Update</p>	<p>Explanation Printer firmware update available using the USB storage directly without any communication.</p> <p>File path F:\ FW_DOWNLOAD</p> <p>File name “XT5-4x_Vxx.xx_STD_mmddyy.fls” in F:\ FW_DOWNLOAD folder.</p> <p>• Download process explanation</p> <ul style="list-style-type: none">- Check firmware file(*.fls) is in FW_DOWNLOAD folder of USB storage. (If there is no folder, please create FW_download folder and save the firmware file (*.fls) to it.)- Connect USB storage to the printer.- Select “F/W Update” from the “Files” menu.- Select the firmware download menu.- If the message "F/W Downloading" is displayed, the firmware download has started normally.- When the firmware download is completed successfully, the message "Printer Restart" is displayed and the rebooting process is automatically performed.
--------------------------	--

4-11 Tools Menu Explanation(Standard, Touch Screen Model)

List		Explanation
Self Test		Explanation Prints for self-test
Factory Reset		Explanation Initializes the printer settings to factory default
Dump Mode		Explanation Diagnoses communication status when printing is not normal Default Value Disable Variable Value Disable, Enable
Print Head Check		Explanation Dot-out check of head through printing
LCD	Dead Pixel Test	Explanation LCD pixel test function
	Touch Position Test	Explanation LCD touch position test function (Touch Position Test is supported on Touch Screen Model only)
	Backlight Brightness	Explanation Setting backlight brightness Default Value 70 Variable Value 10 ~ 100
Real Time Clock		Explanation Setting RTC date and time Setting RTC date and time format Date format YYYY-MM-DD, YYYY/MM/DD, MM-DD-YYYY, MM/DD/YYYY, DD-MM-YYYY, DD/MM/YYYY Time format 12H, 24H

Language Setting	Explanation Setting language to be displayed on the LCD Default Value English Variable Value English, Korean, German, French, Spanish
Emulation	Explanation Setting printer emulation Default Value AUTO Variable Value AUTO(SLCS, BPL-Z, BPL-E), BPL-D
USB Serial Number	Explanation Checks USB serial number
Buzzer Setting	Explanation Setting beep on / off Default Value Enable Variable Value Enable, Disable
Security	Explanation Setting a password to restrict printer settings Default Value Disable Variable Value Disable, Enable
Demo Print	Explanation Demo format output function

4-12 Info Menu Explanation(Standard, Touch Screen Model)

List	Explanation
Printer Info	Explanation Checking the printer usage information
Installation & Usage	Explanation Site linking(QR code) for installation and usage instructions
Troubleshooting	Explanation Site linking(QR code) for troubleshooting
Contact US	Explanation Site linking(QR code) for technical support

5. Maintenance

5-1 Cleaning Printer

- Due to dust, foreign substances, adhesives, and other contaminants on or inside print head, print quality may be reduced. In this case, clean the printer using the cleaning tools for each area as indicated in the following table.

Area	Tools	Interval
Print Head	Cotton swab dipped in medical alcohol solution	When changing media
Platen Roller	Cloth dipped in medical alcohol solution (Cotton swab)	
Media Sensor		
Ribbon Sensor		
Media Feed Path	Air compressors,	
Ribbon Feed Path	Cloth dipped in medical alcohol solution (Cotton swab)	
Manual cutting	Cloth dipped in medical alcohol solution (Cotton swab)	When a foreign substance is discovered
Peeler Roller(Optional)		When changing media
Peeler Sensor(Optional)		
Auto Cutter(Optional)	Air compressors, Cotton swab dipped in medical alcohol solution	When a foreign substance is discovered

5-2 Cleaning Print Head

- 1) Open the media cover and print head levers and remove the media and ribbon.
- 2) Clean the print head toward both sides from the center using a cotton swab dipped in medical alcohol.
- 3) After cleaning, use the printer after alcohol has evaporated sufficiently (1 to 2 minutes) and the surface of print head has completely dried up.

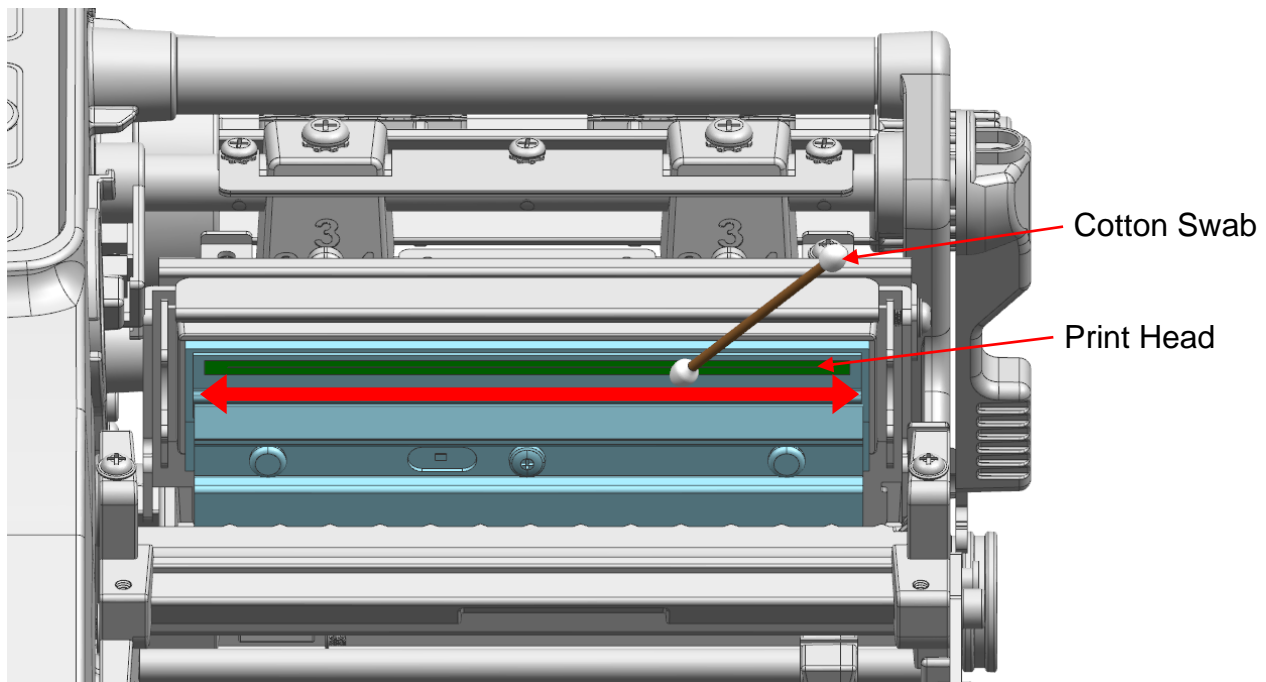

Caution

- Be sure to clean after turning the printer off.
- Be careful not to leave scratches in the print head
The printer may be damaged.
- Print head is very hot while the printer is printing, so clean the printer after cooling it sufficiently with power off.

Warning

Do not touch heated area of print-head when cleaning. Personal injury may result from static electricity, etc.

5-3 Cleaning Platen Roller

- 1) Open the media cover and print head levers and remove the media and ribbon.
- 2) While rotating the roller, remove dust or foreign substances using a dry cloth or cotton swab.
- 3) In case that adhesive substances or other contaminants remain, remove it using a cloth or cotton swab dipped in medical alcohol solution while rotating the roller.
- 4) After cleaning, use the printer after alcohol has evaporated sufficiently (1 to 2 minutes) and the surface of platen roller has completely dried up.

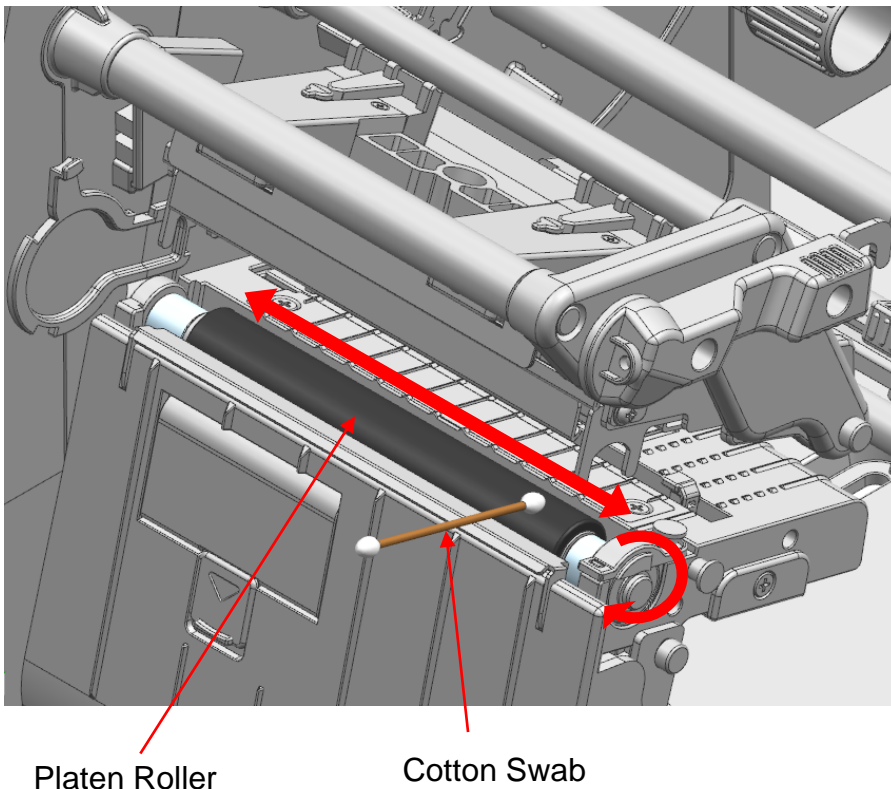
**Caution**

- Be sure to clean after turning the printer off.
- Be careful not to scratch the roller. The printer may be damaged.

5-4 Cleaning Auto Cutter (optional)

- 1) Open the media cover and print head levers and remove the media and ribbon.
- 2) After exposing the cutter blade completely by rotating the knob, remove dust or foreign substances using a cotton swab dipped in medical alcohol solution.

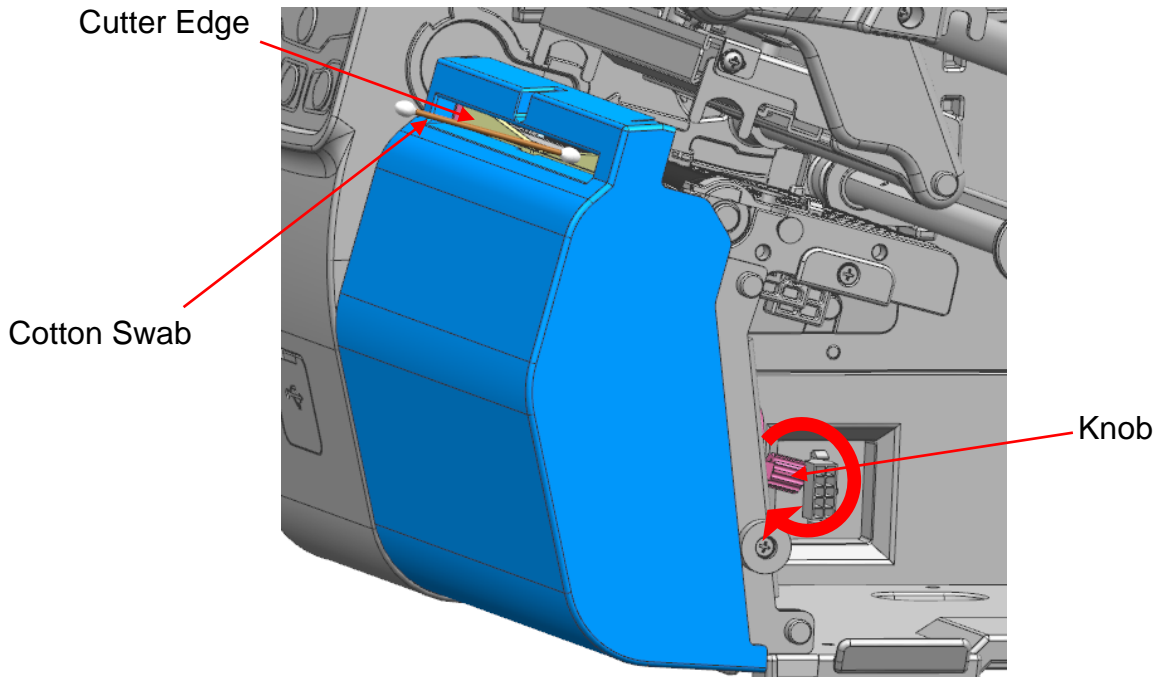

- 3) After cleaning, use the printer after alcohol has evaporated sufficiently (1 to 2 minutes) and the cutter blade has completely dried up.

⚠ Caution

- Be sure to clean after turning the printer off.
- Be careful not to scratch the cutter blade.
The printer may be damaged.

⚠ Warning

**Do not touch cutter edge of auto cutter when cleaning.
This can cause serious bodily injury.**

5-5 Cleaning Peeler Module (optional)

- 1) Open the media cover, print head levers, and peeler cover and remove the media and ribbon.
- 2) While rotating the roller, remove dust or foreign substances using a dry cloth or cotton swab.
- 3) In case that adhesive substances or other contaminants remain, while rotating the roller, remove it using a cloth or cotton swab dipped in medical alcohol solution.
- 4) After cleaning, use the printer after alcohol has evaporated sufficiently (1 to 2 minutes) and the surface of roller has completely dried up.

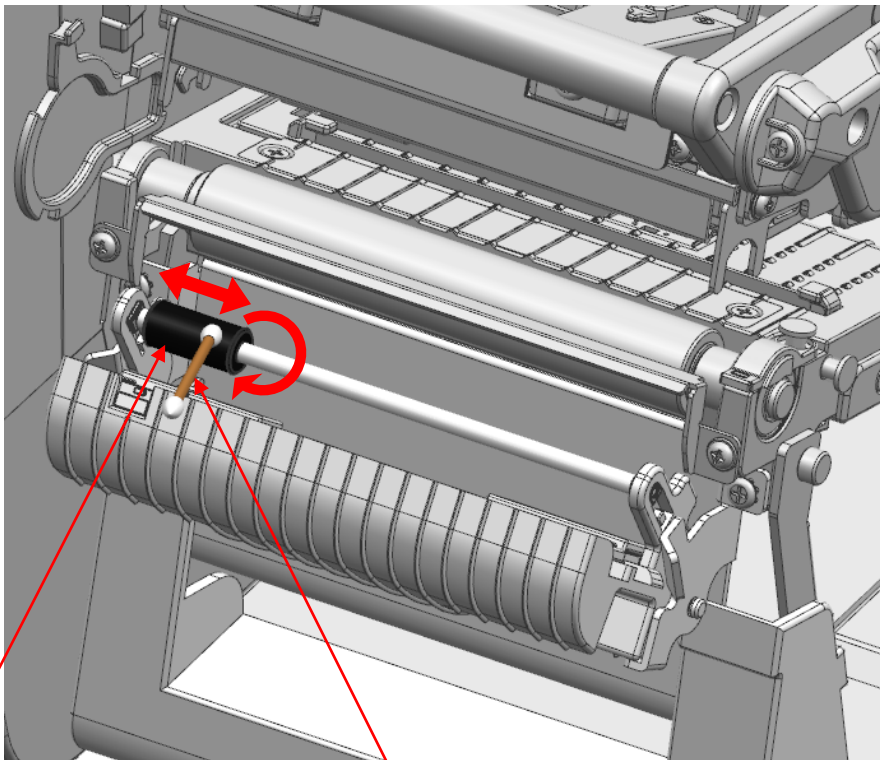

Roller

Cotton Swab



Caution

- Be sure to clean after turning the printer off.
- Be careful not to scratch the roller. The printer may be damaged.

6. Printer Specifications

6-1 Specifications

Item		Description
Printer	Printing Method	Thermal transfer Printing
	Dot Density	XT5-40: 203dpi (8 dot/mm) XT5-43: 300dpi (11.8 dot/mm) XT5-46: 600dpi (23.6 dot/mm)
	Print Width	XT5-40: Max 104mm (Max 4.09") XT5-43: Max 105.7mm (Max 4.16") XT5-46: Max 105.6mm (Max 4.15")
	Print Speed	XT5-40: Max 356mm/sec (Max 14ips) XT5-43: Max 254mm/sec (Max 10ips) XT5-46: Max 127mm/sec (Max 5ips)
Media	Width	25 ~ 114mm
	Outer Diameter	Max 203mm
	Inner Diameter	38.1~76.2mm (1.5 ~ 3 Inch), 25.4mm (1 Inch Option)
Ribbon	Length/Width	Max 450m / 40 ~ 110mm (1.6 ~ 4.3 Inch)
	Type	Wax, Wax resin, Resin, Outside, Inside
	Inner Diameter	25.4mm (1 Inch)
AC/DC Enclosed	Input Voltage	AC 100~120V / AC 200~240V
	Input Frequency	50/60Hz
	Output Voltage/ Current	DC 24V / 7.5A
Usage Conditions	Temperature	5~ 40 °C (Operating) -20 ~ 60 °C (Storage)
	Humidity (except for Media)	10 ~ 80 % RH (Operating) 10 ~ 90 % RH (Storage)



Note

Print speed may vary depending on the data transfer speed and the combination of command.



Caution

- In case of danger, turn off the power to cut the connection.
- The power cord must be grounded to ensure safety and reduce electromagnetic interference

6-2 Label Types

- The label types used with this printer are as follows.
 - Control Labels: PET
 - Other Labels: PP, PET

Copyright

© BIXOLON Co., Ltd. All rights reserved.

This user manual and all property of the product are protected under copyright law. It is strictly prohibited to copy, store, and transmit the whole or any part of the manual and any property of the product without the prior written approval of BIXOLON Co., Ltd. The information contained herein is designed only for use with this BIXOLON product. BIXOLON is not responsible for any direct or indirect damages, arising from or related to use of this information.

- The BIXOLON logo is the registered trademark of BIXOLON Co., Ltd.
- All other brand or product names are trademarks of their respective companies or organizations.

BIXOLON maintains ongoing efforts to enhance and upgrade the functions and quality of all our products. In the following, product specifications and/or user manual content may be changed without prior notice.

Notice - EU

This wireless device is class A that is considered to be used in an industrial environment.

Caution

Electronics, such as printers, are prone to damage by static electricity. Therefore, to protect the printer from static electricity, be sure to turn off the printer before connecting or disconnecting the cable to the rear of the printer. If the printer is damaged by static electricity, contact your local dealer.

This equipment is not suitable for use in locations where children are likely to be present. When the printer is operating with the media cover open, do not wear anything that can touch the drive, such as clothing, necklaces, rings, watches, or employee certificates close to it. Also, keep yourself away from the printer as it is dangerous for some parts of the body to come into contact with it. If an object or part of your body touches the drive, immediately disconnect the power cord or turn off the power switch on the back of the product.

If the battery is not replaced correctly, there is a risk of explosion. Replace only with the same model or equivalent product specified by the manufacturer. When the battery is used up, be sure to tape the terminals and insulate them and dispose at the designated place in accordance with the relevant laws and ordinances set by the state.

Warning

Hazardous moving parts
Keep fingers and other body parts away
Pull the print head lever can be stop all moving parts.



IEC 60417-6057 (2011-05) for other moving parts.

Mise en garde

Les appareils électroniques, tels que les imprimantes, risquent d'être endommagés par l'électricité statique. Par conséquent, pour protéger l'imprimante de l'électricité statique, veuillez à l'éteindre avant de connecter ou de déconnecter le câble situé à l'arrière de celle-ci. Si l'imprimante est endommagée par l'électricité statique, contactez votre revendeur local

Cet appareil n'est pas adapté d'utiliser dans des endroits où des enfants sont probablement d'être présents.

Lorsque l'imprimante fonctionne avec le capot ouvert, ne portez rien qui puisse entrer en contact avec le mécanisme, tel que des vêtements, des colliers, des bagues, des montres ou des certificats d'employé à proximité. Éloignez-vous également de l'imprimante car il est dangereux que certaines parties du corps entrent en contact avec celle-ci. Si un objet ou une partie de votre corps entre en contact avec le mécanisme, débranchez immédiatement le câble d'alimentation ou éteignez l'interrupteur situé à l'arrière du produit.

Si la batterie n'est pas remplacée correctement, il existe un risque d'explosion. Remplacez-la uniquement avec le même modèle ou un produit équivalent approuvé par le fabricant. Lorsque la batterie est épuisée, veuillez à coller du ruban adhésif sur les bornes, à l'isoler et à la jeter de manière adéquate, conformément aux lois et réglementations locales et nationales en vigueur.

Attention

Pièces mobiles dangereuses

Veillez à ce que vos doigts ou toute partie du corps n'entre(nt) pas en contact avec ces pièces.
Tirez le levier de la tête d'impression pour arrêter toutes les pièces en mouvement.



IEC 60417-6057 (2011-05) pour les autres pièces mobiles.

Compliance information

This device complies with Part 15 of the FCC Rules. Operation is subject to the following two conditions: (1) This device may not cause harmful interference, and (2) This device must accept any interference received, including interference that may cause undesired operation.

This equipment has been tested and found to comply with the limits for a Class A digital device pursuant to Part 15 of the FCC Rules. These limits are designed to provide reasonable protection against harmful interference when the equipment is operated in a commercial environment. This equipment generates uses, and can radiate radio frequency energy and, if not installed and used in accordance with the instruction manual, may cause harmful interference to radio communications. Operation of this equipment in a residential area is likely to cause harmful interference in which case the user will be required to correct the interference at his own expense.

Caution: Exposure to Radio Frequency Radiation.

To comply with FCC RF exposure compliance requirements, a separation distance of at least 20 cm must be maintained between the antenna of this device and all persons.

Caution: Any Changes or modifications not expressly approved by the manufacturer could void the user's authority to operate the equipment.

Class A Digital Device : Wired Device

This Apparatus complies with class "A" limits for radio interference as specified in the Canadian department of communications radio interference regulations.

This Class A digital apparatus complies with Canadian ICES-003.

Appareil numérique de classe A: appareil filaire

Get appareil est conforme aux normes class "A" d'interference radio tel que specifier par ministre canadien des communications dans les reglements d'interference radio.

Cet appareil numérique de la classe A est conform à la norme NMB-003 du Canada.

Waste Electrical and Electric Equipment (WEEE)



This marking shown on the product or its literature, indicates that is should not be disposed with other household wastes at the end of its working life, To prevent possible harm to the environment or human health from uncontrolled waste disposal, please separate this from other types of wastes and recycle it responsibly to promote the sustainable reuse of material resources. Household users should contact either the retailer where they purchased this product, or their local government office, for details of where and how they can take this item for environmentally safe recycling. Business users should contact their supplier and check the terms and conditions of the purchase contract. This product should not be mixed with other commercial wastes for disposal.

Revision History

Rev.	Date	Page	Description
1.00	16.10.18	-	New
1.01	17.10.19	11	Media Damper, Media Damper Button named added.
		12	Peeler model image added.
		13,17	Printer operation button image revised.
		28	Media Installation (Removal) Method - Not Using Media Core added.
		31	Media Installation Method of Peeler (optional) Model added.
		34	Media Installation Method of Peeler + Rewinder (optional) Model changed.
		43	How to Use Media Damper (Standard Model) added.
		47	"using a sharp tool" deleted.
		48	Description of print density added.
		49,50,51	Printer operation button image revised and Print head adjustment instruction added.
1.02	06.12.19	53	WLAN section added.
		55	Installation & Usage section added.
		67	WLAN section added.
		69	Sensor menu reference added.
		77	Print head cleaning tool revised.
		78	Print head cleaning instructions and images revised
		85	Warning contents revised
		1.03	07.09.20
2	Introduction revised		
5	Manual Information revised.		
6	Symbol Information revised.		
9	Touch Screen Model image added		
18~21	Major Control Part Names (Touch Screen Model) added.		
23	Power Connection revised.		
58~60	Menu Composition (Standard Model) revised.		
61~63	Menu Composition (Touch Screen Model) added.		
68~70	Menu Select Method (Touch Screen Model) added.		
96	Label Types added.		
1.04	11.24.20	98	Caution revised